

420-7108-01UK
1ST PRINTING

SEGA[®]

SEGA AMUSEMENTS EUROPE LTD

Block C, 42 Barwell Business Park, Chessington, SURREY. KT9 2NY. United Kingdom.
TEL: +44 (0)208 391 8090. FAX: +44 (0)208 391 8099

© SEGA

All manufacturers, cars, names, brands and associated imagery featured in this game are trademarks and/or copyrighted materials of their respective owners. All rights reserved.

SEGA-RaceTV

OWNER'S MANUAL

420-7108-01UK

SEGA[®]

OWNER'S MANUAL



IMPORTANT

- Before using this product, read this manual carefully to understand the contents herein stated.
- After reading this manual, be sure to keep it near the product or in a convenient place for easy reference when necessary.

TABLE OF CONTENTS

BEFORE USING THE PRODUCT, BE SURE TO READ THE FOLLOWING:

TABLE OF CONTENTS	i
INTRODUCTION	iv
1 HANDLING PRECAUTIONS	1
2 PRECAUTIONS REGARDING INSTALLATION LOCATION	5
2-1 LIMITATIONS OF USAGE	5
2-2 OPERATION AREA	6
3 PRECAUTIONS REGARDING PRODUCT OPERATION	7
4 PART DESCRIPTIONS	11
5 ACCESSORIES	12
6 ASSEMBLY AND INSTALLATION	14
6-1 INSTALLATION AND SECURING IN PLACE	16
6-1-2 INSTALLATION OF THE AC COVERS	17
6-1-3 ASSEMBLE FRONT DESIGN PLATE	18
6-1-4 SECURING IN POSITION	19
6-2 ATTACHING THE DVD DRIVE AND KEY CHIP	20
6-3 CONNECTING POWER AND GROUND	22
6-4 TURNING THE POWER ON	24
6-5 CHECKING ASSEMBLY	30
7 PRECAUTIONS WHEN MOVING THE MACHINE	33
8 GAME DESCRIPTION	35
8-1 GAME OVERVIEW	35
8-2 GAME FLOW	37
8-3 MODE OVERVIEW	40
8-3-1 MULTI PLAYER GAME	40
8-3-2 SINGLE PLAYER GAME	40
8-4 PASSWORDS	41
8-5 TIME RELEASE	42

9	TEST MODE	43
9-1	SWITCH UNIT AND COIN METER	44
9-2	SYSTEM TEST MODE	46
9-3	GAME TEST MODE	47
9-3-1	GAME TEST MODE Menu	47
9-3-2	INPUT TEST	48
9-3-3	OUTPUT TEST	49
9-3-4	FORCE FEEDBACK	50
9-3-5	INPUT ASSIGNMENTS	51
9-3-6	GAME ASSIGNMENTS	55
9-3-7	BOOKKEEPING	57
9-3-8	BACKUP DATA CLEAR	59
10	CONTROL PANEL (HANDLE MECHA)	60
10-1	OPENING THE CONTROL PANEL	61
10-2	ADJUSTING/REPLACING THE VOLUME	62
10-3	GREASING	64
11	SHIFT LEVER	65
11-1	REMOVING THE SHIFT LEVER	65
11-2	SWITCH REPLACEMENT	66
12	ACCELERATOR & BRAKE	67
12-1	VOLUME ADJUSTMENT AND REPLACEMENT	68
12-2	GREASING	70
13	COIN HANDLING AND CREDIT SETTING	71
14	MONITOR	79
14-1	CAUTIONS AND WARNINGS CONCERNING THE SAFETY FOR HANDLING THE MONITORS	79
14-2	CLEANING THE CRT SURFACES	82
14-3	ADJUSTMENT PROCEDURE	83
15	FLUORESCENT LIGHT/OTHER LAMPS REPLACEMENT	86
16	PERIODIC INSPECTION	89
17	TROUBLESHOOTING	91
17-1	TROUBLESHOOTING (WHEN NO ERROR MESSAGE IS SHOWN)	91
17-2	ERROR MESSAGES	95
18	GAME BOARD	97
18-1	REMOVING THE LINDBERGH	98
18-2	COMPOSITION OF THE GAME BOARD	100

19 COMMUNICATION PLAY 101

 19-1 INSTALLATION PRECAUTIONS101

 19-2 CONNECTING THE COMMUNICATION CABLE103

 19-3 NETWORK PLAY SETTINGS106

 19-4 NETWORK PLAY PRECAUTIONS107

 19-5 ATTACHING SATELLITE NUMBER STICKERS108

20 DESIGN-RELATED PARTS..... 109

21 PARTS LIST..... 110

22 WIRE COLOR CODE TABLE..... 140

23 WIRING DIAGRAM..... 141

INTRODUCTION

This manual is intended to provide detailed descriptions together with all the necessary information covering the general operation of electronic assemblies, electro-mechanicals, servicing control, spare parts, etc. for the product, "SEGA-RaceTV."

This manual is intended for the owners, personnel and managers in charge of operation of the product. Operate the product after carefully reading and sufficiently understanding the instructions.

In the unlikely event that the product does not function correctly, DO NOT allow anyone other than a technician to touch the internal system. Turn off the power to the machine, making sure to unplug the electrical cord from the outlet, and contact the office listed below or the point of purchase for this product.

Use of this product is unlikely to cause physical injuries or damage to property. However, points that require special attention are indicated by bold text, the word "IMPORTANT" and the symbol below.



Indicates important information that, if ignored, may result in the mishandling of the product and cause faulty operation or damage to the product.

Sega Amusements U.S.A., Inc.
800 Arthur Avenue, Elk Grove Village, IL 60007-5215, U.S.A.

TEL: 1-847-364-9787
TOLL FREE: 1-888-877-2669
FAX: 1-847-427-1065

SEGA AMUSEMENTS EUROPE, LTD.
42, Barwell Business Park, Leatherhead Road, Chessington, Surrey, KT9 2NY United Kingdom

Telephone: +44 (0) 208 391 8090 Facsimile: +44 (0) 208 391 8099
e-mail: mailbox@sega.co.uk <http://www.sega-amusements.co.uk>

SPECIFICATIONS

Installation space:	928 mm (36.5 in.) [Width] x 1,756 mm (69.1 in.) [Depth]
Height:	2,192 mm (86.3 in.)
Weight:	255 kg (562.2 lbs.)
Power, maximum current:	458 W, 4.34 A (AC 120 V, 60 Hz Area) 464 W, 2.40 A (AC 220 V, 50 Hz Area) 460 W, 2.20 A (AC 220 V, 60 Hz Area) 462 W, 2.30 A (AC 230 V, 50 Hz Area) 472 W, 2.19 A (AC 240 V, 50 Hz Area)
Power, current:	474 W, 5.1 A, (Max.) (AC 110 V, 60 Hz; Taiwan) 265 W, 2.6 A, (Min.) (AC 110 V, 60 Hz; Taiwan)
Monitor:	29 Type Color Monitor

NOTE: The contents herein described are subject to change without notice.

Definition of 'Site Maintenance Personnel or Other Qualified Individuals'

WARNING

Procedures not described in this manual or marked as 'to be carried out by site maintenance personnel or other qualified professionals' should not be carried out by personnel without the necessary skill or technology. Work carried out by unqualified persons may cause serious accidents, including electrocution.

Parts replacement, maintenance inspections and troubleshooting should be carried out by site maintenance personnel or other qualified professionals. This manual includes directions for potentially dangerous procedures which should only be carried out by professionals with the appropriate specialized knowledge.

The site maintenance personnel or other qualified professionals mentioned in this manual are defined as follows:

Site maintenance personnel:

Individuals with experience in maintaining amusement equipment, vending machines, etc., working under the supervision of the owner/operator of this product to maintain machines within amusement facilities or similar premises by carrying out everyday procedures such as assembly, maintenance inspections, and replacement of units/expendable parts.

Activities to be carried out by site maintenance personnel:

Amusement equipment/vending machine assembly, maintenance inspection and replacement of units/expendable parts.

Other qualified professionals:

Persons employed by amusement equipment manufacturers, or involved in design, production, testing or maintenance of amusement equipment. The individual should have either graduated from technical school or hold similar qualifications in electrical/electronics/mechanical engineering.

Activities to be carried out by other qualified professionals:

Amusement equipment/vending machine assembly, repair/adjustment of electrical/electronic/mechanical parts.

1 HANDLING PRECAUTIONS

When installing or inspecting the machine, be very careful of the following points and pay attention to ensure that the player can enjoy the game safely.

Non-compliance with the following points or inappropriate handling running counter to the cautionary matters herein stated can cause personal injury or damage to the machine.

WARNING

- Before performing work, be sure to turn the power off. Performing the work without turning the power off can cause an electric shock or short circuit. In the case work should be performed in the status of power on, this manual always states to that effect.
- To avoid an electric shock or short circuit, do not plug in or unplug quickly.
- To avoid an electric shock, do not plug in or unplug with a wet hand.
- Do not expose power cords or earth wires on the surface, (floor, passage, etc.). If exposed, the power cords and earth wires are susceptible to damage. Damaged cords and wires can cause an electric shock or short circuit.
- To avoid causing a fire or an electric shock, do not put things on or damage the power cords.
- When or after installing the product, do not unnecessarily pull the power cord. If damaged, the power cord can cause a fire or an electric shock.
- In case the power cord is damaged, ask for a replacement through where the product was purchased from or the office herein stated. Using the cord as is damaged can cause fire, an electric shock or leakage.
- Be sure to perform grounding appropriately. Inappropriate grounding can cause an electric shock.
- Be sure to use fuses meeting the specified rating. Using fuses exceeding the specified rating can cause a fire or an electric shock.
- Be sure that connections such as IC BD are made properly. Insufficient insertion can cause an electric shock.
- Specification changes, removal of equipment, conversion and/or addition, not designated by SEGA are not permitted.
- Failure to observe this may cause a fire or an electric shock. Non-compliance with this instruction can have a bad influence upon physical conditions of the players or the onlookers, or result in injury during play.
- SEGA shall not be held responsible for damage, compensation for damage to a third party, caused by specification changes not designated by SEGA.
- If work or parts replacement not indicated in this manual is carried out, an accident may occur. If it is necessary to carry out work not indicated in this manual, be sure to have it done by the office indicated in this manual or by the point of purchase. Also, please inquire regarding details of the work involved.
- Be sure to perform periodic maintenance inspections herein stated.

STOP IMPORTANT

1 HANDLING PRECAUTIONS

- For the IC board circuit inspections, only the logic tester is allowed. The use of a multiple-purpose tester is not permitted, so be careful in this regard.
- When cleaning the CRT surfaces, use a soft and dry cloth. Do not apply chemicals such as thinners, benzene, etc.
- Static electricity from your body may damage some electronics devices on the IC board. Before handling the IC board, touch a grounded metallic surface so that the static electricity can be discharged.
- Do not turn the power on and off continuously. Repeatedly turning the power on and off may cause product malfunction or parts damage.
- Some parts are not designed and manufactured specifically for this game machine. The manufacturers may discontinue, or change the specifications of such general-purpose parts. If this is the case, SEGA cannot repair or replace a failed game machine whether or not a warranty period has expired.

CONCERNING THE STICKER DISPLAY

This SEGA product has stickers attached describing the product manufacture No. (Serial No.) and Electrical Specifications. It also has a Sticker describing where to contact for repair and for purchasing parts.

When inquiring about or asking for repairs, mention the Serial No. and Name of Machine indicated on the Sticker. The Serial Number indicates the product register. Identical machines could have different parts depending on the date of production. Also, improvements and modifications might have been made after the publication of this manual. In order to ensure you order the correct parts, mention the Serial No. when contacting the applicable places.

CONCERNING THE WARNING LABELS

This SEGA product has warning displays on stickers, labels and/or printed instructions adhered/attached to or incorporated in the places where a potentially hazardous situation could arise. The warning displays are intended for accident prevention for customers and for avoiding hazardous situations relating to maintenance and servicing work. Some portions of the cabinet contain high voltage and may cause accidents if touched.

When performing maintenance, be very careful of the warning displays. It is especially important that any complex repair and replacement work not mentioned herein should be performed by those technical personnel who have knowledge of electricity and technical expertise. In order to prevent accidents, caution any customer ignoring the warnings to cease and desist immediately

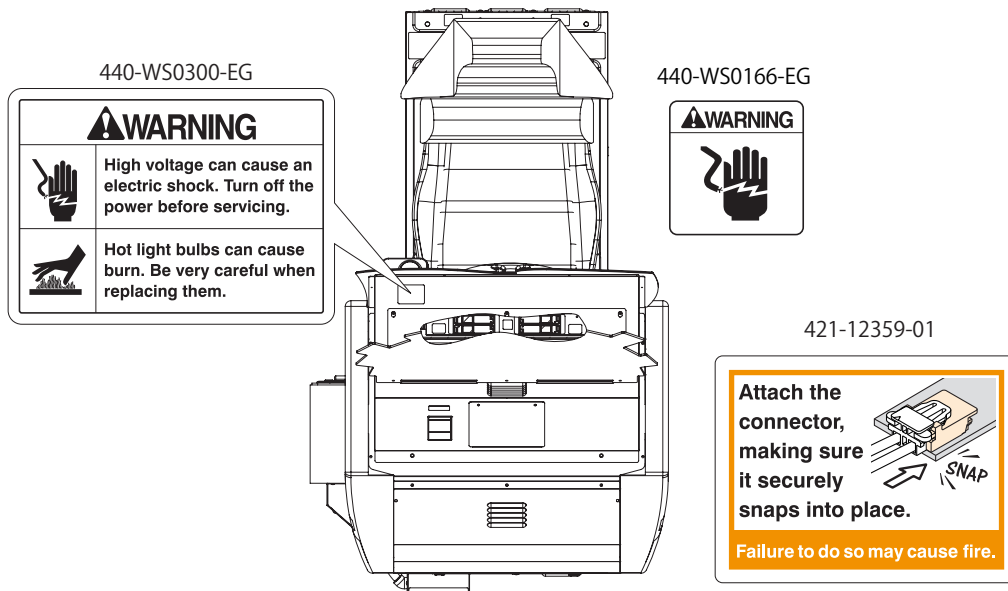

440-DS0013XEG

⚠ DANGER



Hazardous voltage can cause severe injury or death even after power off. Do not touch the monitor.

440-CS0186-EG

⚠ CAUTION

- If you or your child might have experienced a convulsive attack, loss of consciousness, etc. due to light stimulus or TV games, or might be feared to experience such symptoms, be very careful of using the machine.
- If you feel sick while playing the game, immediately discontinue use and take a rest.

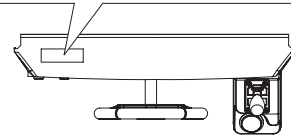

SEE A

440-WS0002XEG

⚠ WARNING



High voltage can cause an electric shock. Turn off power before servicing.

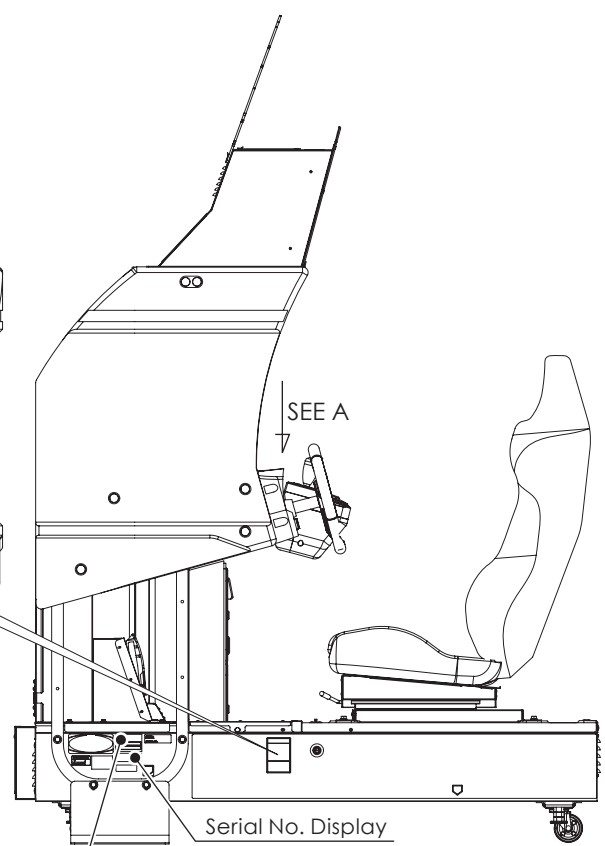
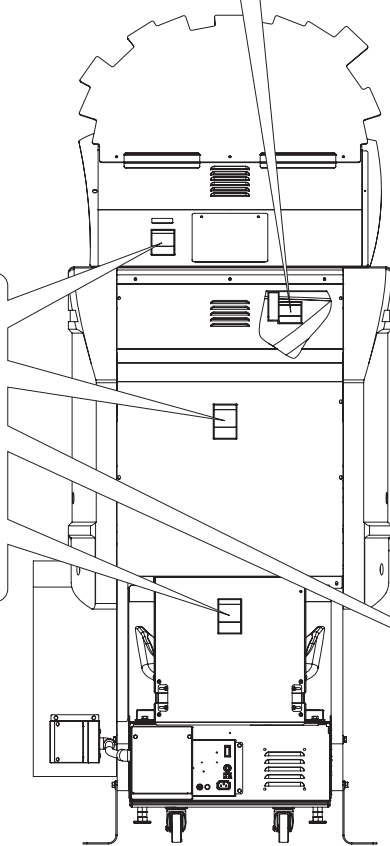

SEE A

Serial No. Display

Electrical Specifications Display

2 PRECAUTIONS REGARDING INSTALLATION LOCATION

WARNING

This product is an indoor game machine. Do not install it outside. Even indoors, avoid installing in places mentioned below so as not to cause a fire, electric shock, injury and/or malfunction.

- Places subject to rain or water leakage, or places subject to high humidity in the proximity of an indoor swimming pool and/or shower, etc.
- Places subject to direct sunlight, or places subject to high temperatures in the proximity of heating units, etc.
- Places filled with inflammable gas or vicinity of highly inflammable/volatile chemicals or hazardous matter.
- Dusty places.
- Sloped surfaces.
- Places subject to any type of violent impact.
- Vicinity of anti-disaster facilities such as fire exits and fire extinguishers.
- Areas where the temperature exceeds the applicable temperature (ambient temperature) range of 5 to 30 degrees centigrade.

2.1 LIMITATIONS OF USE

WARNING

Be sure to check the Electrical Specifications. Ensure that this product is compatible with the location' s power supply, voltage, and frequency requirements. A plate describing Electrical Specifications is attached to the product. Non-compliance with the Electrical Specifications can cause a fire and electric shock.

This product requires a breaker and earth mechanism as part of the location facilities. Using the product without these can cause a fire and electric shock.

Ensure that the indoor wiring for the power supply is rated at 15 A or higher (AC single phase 100 V ~ 120 V area), and 7 A or higher (AC 220 V ~ 240 V area). Non-compliance with the Electrical Specifications can cause a fire and electric shock.

Be sure to use an independent power supply equipped with an earth leakage breaker. Using a power supply without an earth leakage breaker can cause an outbreak of fire if a power surge occurs.

Putting many loads on one electrical outlet can cause generation of heat and a fire resulting from overload.

When using an extension cord, ensure that the cord is rated at 15 A or higher (AC 100 V ~ 120 V area) and 7 A or higher (AC 220 V ~ 240 V area). Using a cord rated lower than the specified rating can cause a fire and electric shock.

ELECTRICITY CONSUMPTION

MAX: 3.5A (AC220V~240V 60Hz)

2.2 OPERATION AREA

⚠ WARNING

- For the operation of this machine, secure a minimum area of 2.2 m [W] x 2.3 m [D]. The dimensions of the base periphery are established in consideration of ventilation, maintenance and customer passage. And if they fall and hit their head, there could be a very serious injury. Be sure to always secure enough space as prescribed in this manual.
- Be sure to provide sufficient space specified in this manual. Do not allow objects to block the ventilation ports. It can cause generation of heat and a fire.
- SEGA shall not be held responsible for damage or compensation for damage to a third party, resulting from the failure to observe this instruction.

STOP IMPORTANT

In order to transport the machine into a building, the minimum necessary dimensions of the opening (of doors, etc,) are 1.2m, (W) and 1.8m, (H).

INSTALLATION SPACE

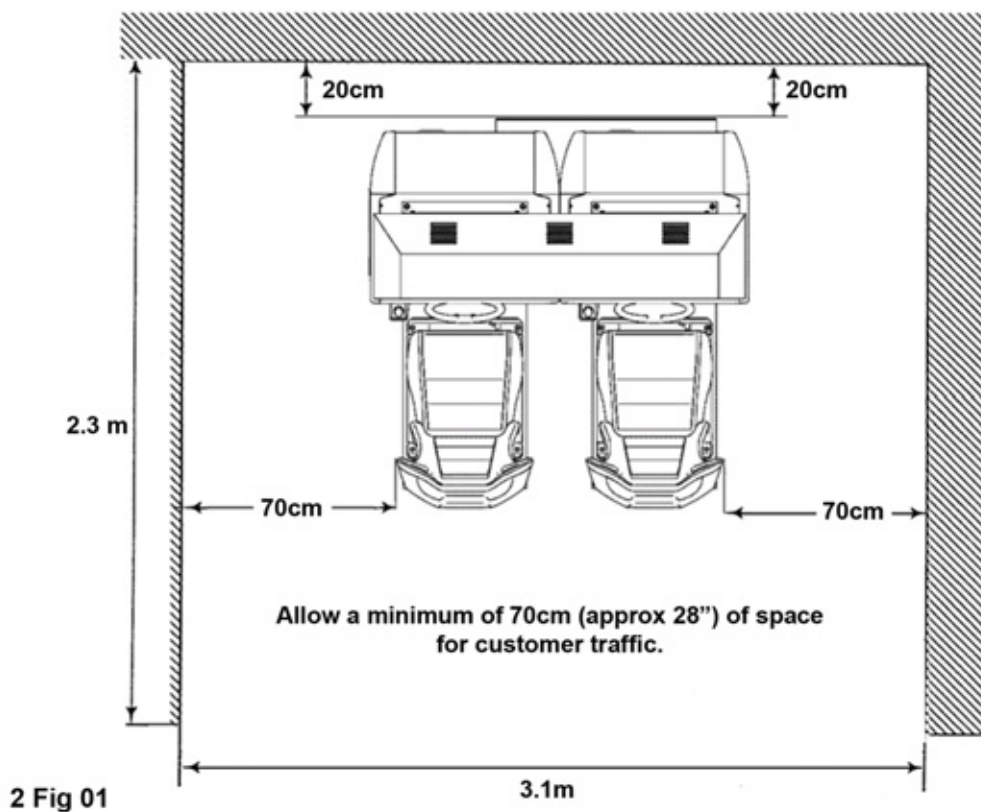

3 PRECAUTIONS REGARDING PRODUCT OPERATION

To avoid injury and trouble, be sure to pay attention to the behavior of visitors and players

⚠ WARNING

In order to avoid accidents, check the following before starting the operation:

To ensure maximum safety for the players and the customers, ensure that where the product is operated has sufficient lighting to allow any warnings to be read.

Operation under insufficient lighting can cause bodily contact with each other, hitting accident, and/or trouble between customers.

Be sure to perform appropriate adjustment of the monitor (projector). For operation of this machine, do not leave monitor's flickering or deviation as is. Failure to observe this can have a bad influence upon the players' or the customers' physical conditions.

It is suggested to ensure a space allowing the players who feel sick while playing the game to take a rest.

Check if all of the adjusters are in contact with the surface. If they are not, the cabinet can move and cause an accident.

Do not put any heavy items on this product. Placing any heavy item on the product can cause a falling down accident or parts damage

Do not climb on the product. Climbing on the product can cause a falling down accident. To check the top portion of the product, use a step ladder.

To avoid electric shock, short circuit and / or parts damage, do not put the following items on or in the periphery of the product.

Flower vases, flower pots, cups, water tanks, cosmetics, receptacles or vessels containing chemicals or water.

Ensure that all adjusters are in contact with the floor.

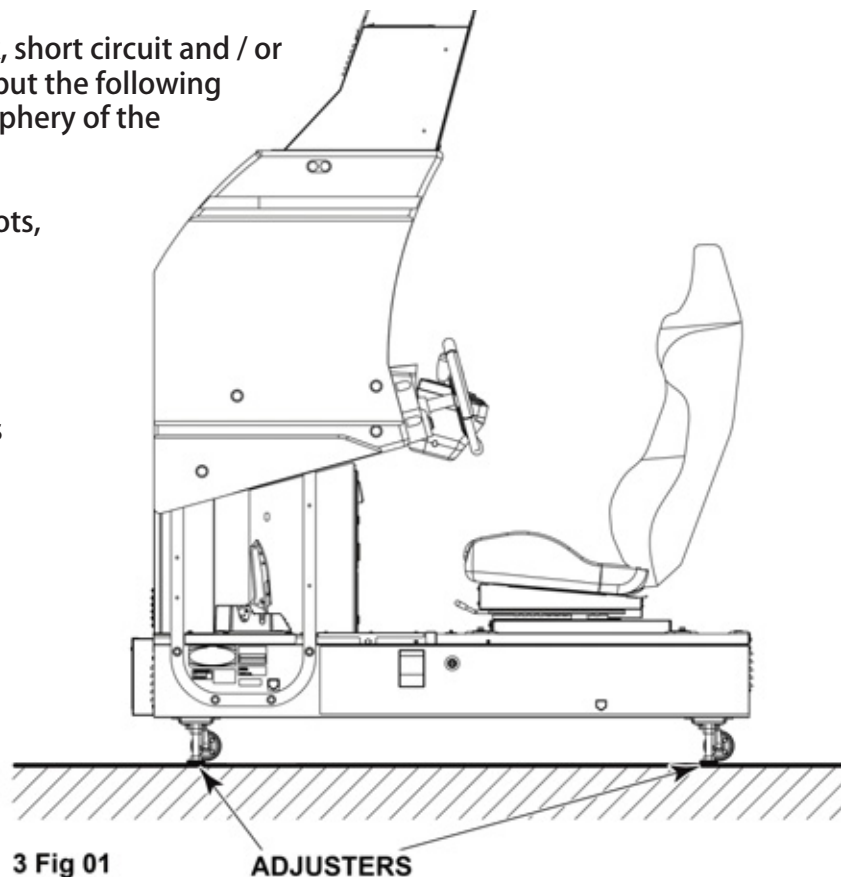

⚠ CAUTION

- During daily cleaning be sure to check the surface of the steering wheel, gear shifter and other parts that the player touches with his hands for damage, cracks or loose screws. If a player uses the machine while it is damaged, cracked or has a loose screw, the player may become injured.
- During daily cleaning, be sure to check the seat for any abnormality, wetness, etc. Failure to do this may result in deliberate tampering or negligence being left undetected.
- To avoid injury, be sure to provide sufficient space by considering the potentially crowded situation at the installation location. Insufficient installation space can cause contact, collisions and or trouble between customers.
- Do not attempt to clean this product using pressurised equipment such as a jet wash or hose. If for any reason this product becomes wet, do not use until it has completely dried.

STOP IMPORTANT

Players hold the controller with their bare hands so it is recommended that wet towels (paper towels) be provided.

PAYING ATTENTION TO CUSTOMERS DURING OPERATION

To avoid injury and trouble, be sure to pay attention to the behavior of visitors and players.

WARNING

- For safety reasons, do not allow any of the following people to play the game.
 - Those who need assistance when walking.
 - Those who have high blood pressure or heart problems.
 - Those who have a neck or spinal cord problem.
 - Those who have experienced muscle convulsion or loss of consciousness while playing video games, etc.
 - Those who are intoxicated or under the influence of drugs.
 - Pregnant women.
 - Those who are not in good health.
 - Those who do not follow the attendants instructions.
 - Those who cannot grasp the controller unit securely because of immobility in fingers, hands or arms.
 - Persons who disregard the products warning labels.
- Even players who have never been adversely affected by light stimulus might experience dizziness or headaches depending on their physical condition when playing the game. Small children are especially likely to experience these symptoms. Caution guardians of small children to keep watch on their children during play.
- Instruct those who feel sick during play to seek medical advice or examination.
- To avoid injury from falling objects or electric shock hazard from spilt drinks, instruct the player not to place drinks or heavy items on the product.
- To avoid electric shock hazard and short circuit hazard, do not allow customers to put hand or fingers or any other extraneous matter in to the openings of the product or small openings on or around the doors.
- To avoid falls resulting in injury, immediately stop the customer from leaning against or climbing on the product.
- To avoid electric shock and/or short circuit hazard, do not allow customers to unplug the power plug without a justifiable reason.
- This product is intended for 1 Player only. Playing the game by 2 or more Players riding on the seat together can cause falling down and collision accidents by striking heads, hands or elbows.
- Persons other than the player should not be allowed to touch the controls during play. They may brush against or collide with the controls or the player, possibly resulting in accident.

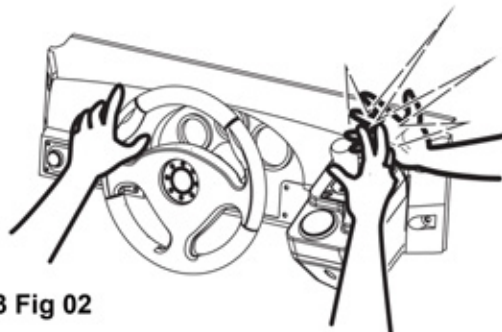

3 Fig 02

⚠ WARNING

- Customer should be warned not to place children on their laps while they play the game. Doing so may cause the child to become trapped between the player and the control panel and/or cause the machine to tip over.

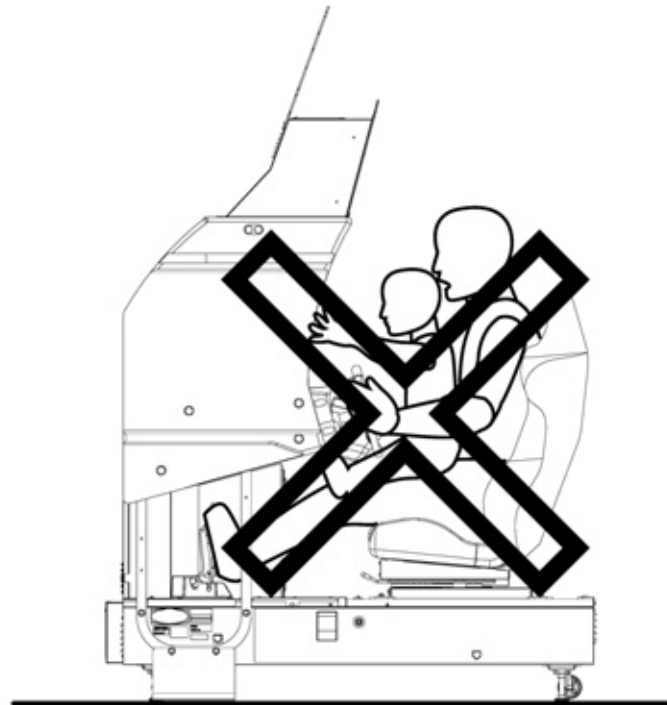

3 Fig 03

⚠ CAUTION

Immediately stop such violent acts as hitting and kicking the product. Such violent acts can cause parts damage or cause the cabinet to fall over, resulting in injury.

4 PART DESCRIPTIONS

Images may differ from the product.

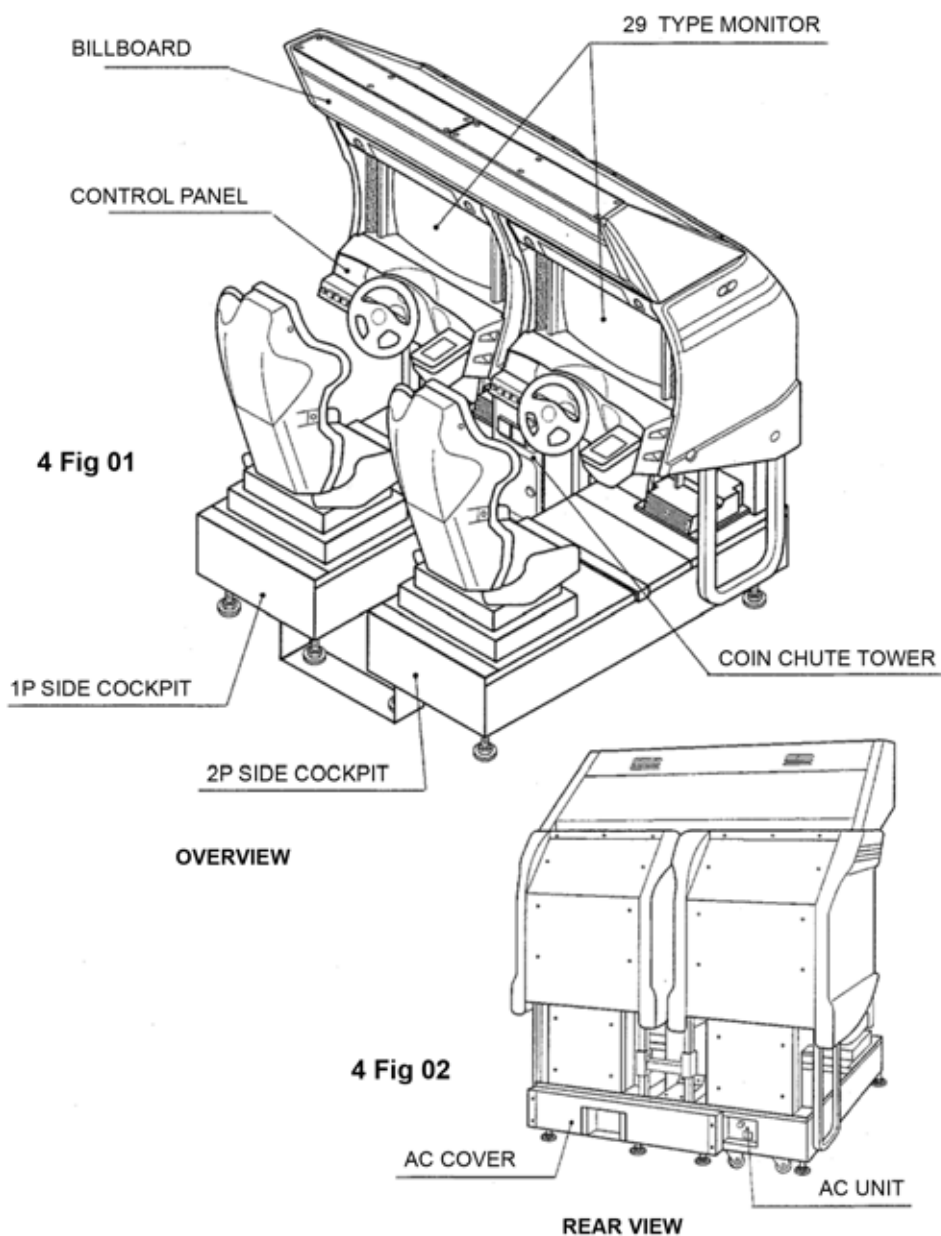

Item	Width (cm)	Length (cm)	Height (cm)	Weight (kg)
COCKPIT	82	164.5	152	228
COIN CHUTE TOWER	30.5	51.5	570	15
BILLBOARD	160.9	61.5	35.4	36
When Assembled	163.2	170	186.4	507 approx

5 ACCESSORIES

Confirm that the accessories list in the table below are present when setting up the product. Accessories marked "Spare" in the note column are consumable items but included as spares.

TABLE 5a - ACCESSORIES

DESCRIPTION	OWNERS MANUAL
PT NUMBER (QTY)	420-7108 (1)
NOTE	This Manual
Parts not labeled with part numbers are as yet unregistered or cannot be registered. Be sure to handle all parts with care, as some parts are not available for purchase as separate items.	

LINDBERGH RED SERVICE MANUAL
420-7032-A001 (1)
Explanation of built in Game Board

TAMPERPROOF SCREW WRENCH
M4 540-0006-01 (1)
M5 540-0007-01 (1)

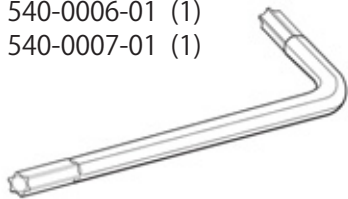

FUSE 3A T 5x20mm
514-5138-1000 (1)

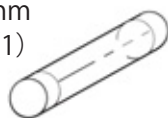

LAMP 6.3V 1W
390-5445-01 (1)

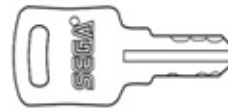

KEY MASTER
220-5793-2-A001 (2)
For opening/closing the doors



KEY (2)
CASHBOX DOOR

MAINS LEADS
LM1227 (1xUK)
LM1246 (1xEURO)

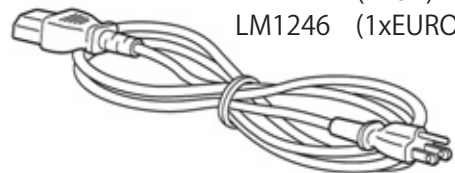

NETWORK (LAN) CABEL
600-7269-0500 (1)



Confirm that the accessories list in the table below are present when setting up the product. Accessories marked "Spare" in the note column are consumable items but included as spares.

TABLE 5b - ACCESSORIES

VOLUMN
220-5484 or 220-5753 (1)

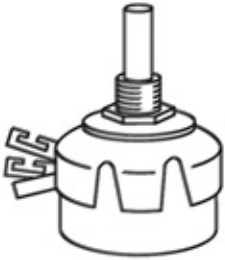

MICROSWITCH
509-5704 (1)



STICKER
421-7308-125 (1)



SATELLITE NUMBER STICKER
RTV-0005 (1)

DVD WIRE FOR LINDBERGH RED (2 m)
605-0094-01 (1)
For software installation, see chapter 6 [8].



NOTE: Use the (2 m) wire included with this product, and not the (1 m) wire included with the DVD DRIVE kit.

6 ASSEMBLY & INSTALLTION

WARNING

- This work should be carried out by site maintenance personnel or other qualified professionals. Work performed by non-technical personnel can cause a severe accident such as electric shock. Failing to comply with this instruction can cause a severe accident such as electric shock to the player during operation. If no one with proper technological expertise is available, request service from the office indicated in this document or the point of purchase so as to ensure safety.
- Perform assembly work by following the procedure herein stated. Failure to comply with the instructions can cause electric shock.
- Perform assembling as per this manual. Since this is a complex machine, incorrect assembling can cause an electric shock, machine damage and/or improper functioning as per specified performance.
- When assembling, more than one person is required. Depending on the assembly work, there are some cases in which working by one person alone can cause personal injury or parts damage.
- Ensure that connectors are properly connected. Improper connections can cause electric shock.
- Be careful not to damage the wires. Damaged wires may cause electric shock or short circuit or present a risk of fire.
- Provide sufficient space so that assembling can be performed. Performing work in places with narrow space or low ceiling may cause an accident and assembly work to be difficult.
- To perform work safely and avoid serious accident such as the cabinet falling down, do not perform work in places where step-like grade differences, a ditch, or slope exist.
- Do not leave power cords, ground wires or network cables in areas of heavy foot traffic. Doing so may cause them to become damaged, possibly resulting in electric shock and/or short circuits. When leaving wiring across a floor, always use safety covers to protect the wires. (Wiring diameter : Power Cables - approx 0.8, Network Cable approx 0.5)
- The power cord for this product has a ground terminal. Make sure to use this ground termination when plugging it into an indoor outlet. Failure to ground the product could lead to electrocution. It can also cause malfunction.
- Do not use connectors other than those connected to and used by the game board at the time of shipment. Do not connect wires to unused connectors. This could cause the generation of heat or smoke, or a burnout.

CAUTION

- Wear appropriate work clothing so that work can be performed safely. Use gloves and safety shoes to prevent accidents or injuries.
- When installing a wire protection cover over a floor, use a material shaped so that no one passing by will stumble over it. Using a material that could be stumbled over might lead to an accidental fall.
- Handle plastic parts with care. Excessive weight or pressure may cause them to break and the broken pieces may cause injury.
- When opening/closing, attaching/removing doors or lids, be careful that your hands or fingers etc, does not get caught in the apparatus.

Installation and assembly of this product should take place in the following sequence.

6-1 INSTALLATION AND SECURING IN PLACE

6-1-2 INSTALLING THE AC COVERS

6-1-3 ATTACHING THE FRONT DESIGN PLATE

6-1-4 SECURING IN POSTION

6-2 ATTACHING THE DVD & KEY CHIP

6-3 CONNECTING THE POWER AND GROUND

6-4 TURNING THE POWER ON

6-4 CHECKING THE ASSEMBLY - SET UP

TOOLS NECESSARY FOR WORK

6-0 Fig 01

MASTER KEY

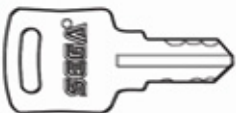

PHILLIPS SCREWDRIVER for M4

**TAMPERPROOF WRENCH
for M4 & M5**

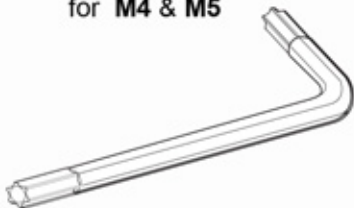

SOCKET HANDLE

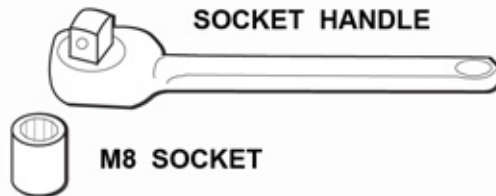

M8 SOCKET

WRENCH with 24mm OPENING JAW



STEP to STAND ON

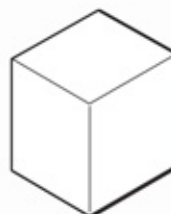

6-1 INSTALLATION AND SECURING IN PLACE

WARNING

ONLY QUALIFIED SERVICE PERSONNEL should carry out this operation

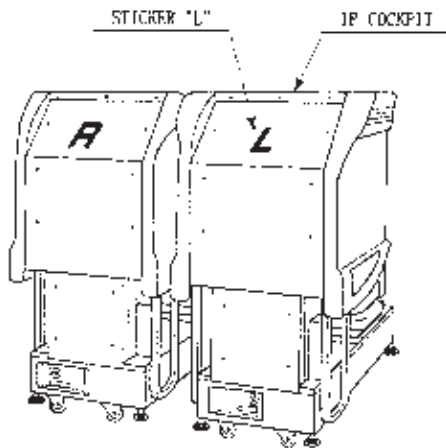

1. Place the two cockpits side by side. Position the 1 player cabinet, which has the IEC inlet at the left hand side when viewed facing the monitor. Sticker "L" is placed on the back of the 1 player cabinet and Sticker "R" is placed on the 2 player cabinet.

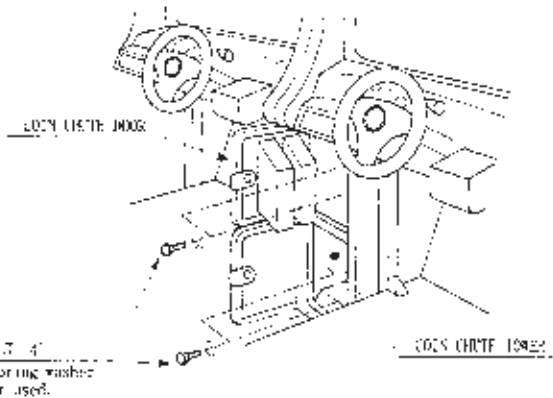

2. Install the Coin Chute Tower between both cabinets. Open the coin door and cash door and secure to both cabinets using the 4x M8 Hex Bolts supplied in the installation kit. At this time make sure that the bolts are only loosely fitted.

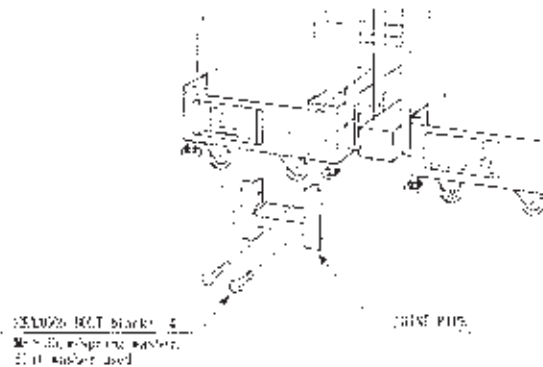

3. Install the Joint Pipe on the rear side of the cabinets by securing using 4x M8 Hex Bolts supplied in the Installation kit, at this time secure loosely.

6-1-2 INSTALLATION OF THE AC COVERS

WARNING

ONLY QUALIFIED SERVICE PERSONNEL should carry out this operation

BE SURE THAT THE MACHINE IS NOT CONNECTED TO THE MAIN SUPPLY BEFORE ATTEMPTING THIS OPERATION.

The AC Wire Covers are used for protecting the interconnecting wiring and the CAT5 LAN cable. When carrying out this operation be careful not to trap and wires between the covers. Pay attention when handling the CAT5 Lan cable as excessive bending will cause damage.

1. Attach AC Cover A to the rear of the cabinets as shown.
2. Make all wiring connections between the two cockpits and the Coin Chute tower. The wiring connectors are tagged and should not be fitted into the locations. Do not force any connectors.
3. Connect the earth wires between the two AC brackets, the AC covers and the Coin Chute Towers.
4. Insert the CAT5 Lan cable from the Left hand cockpit, through the wire cover into the receiving connector within the Right hand AC Bkt.
5. Secure the AC cover C and AC cover D using the screws provided

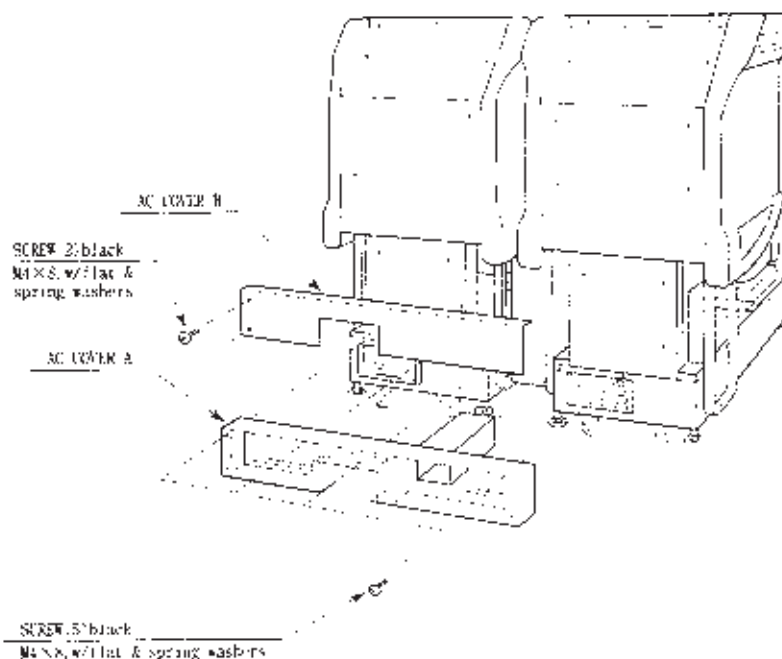

6-1-3 ASSEMBLING FRONT DESIGN PLATE

The FRONT DESIGN PLATE attaches to the ASSY BILLBOARD. Please follow these instructions to secure in place.

The FRONT DESIGN PLATE is located within the ASSY INSTALLATION KIT. Carefully remove the protective and offer up the the front side of the ASSY BILLBOARD.

1. Remove the 4 fixings from the Billboard Box.

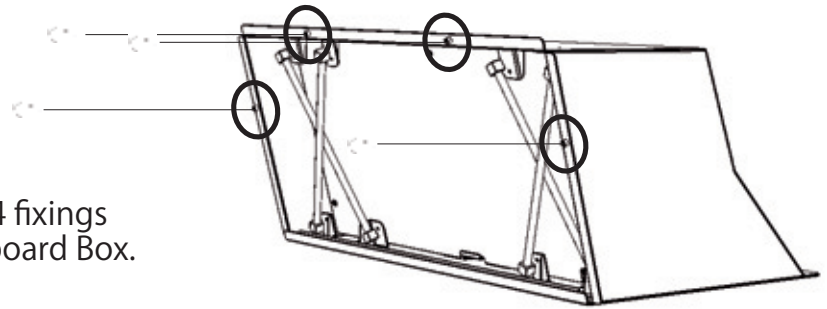

2. Fit the DESIGN PLATE into the groove at the bottom of the BILLBOARD BOX

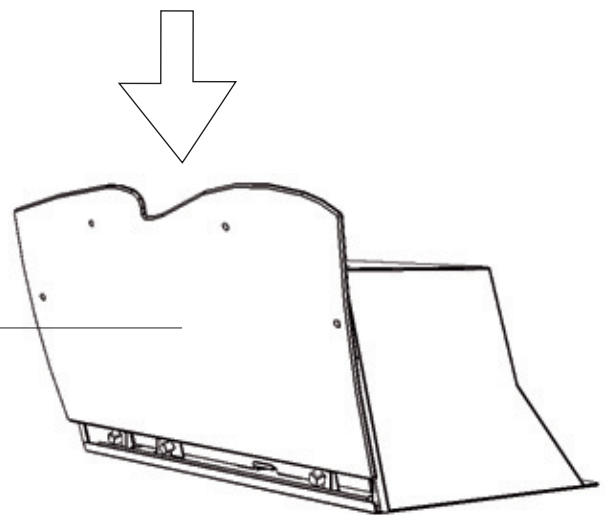

3. Secure the FRONT DESIGN PLATE to the BILLBOARD using the screws removed from step 1.

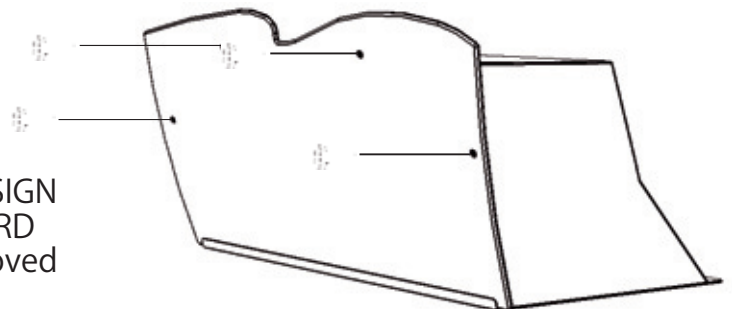

6-1-4 SECURING IN POSITION

RACE TV consists of two individual Game Consols, each consol being fitted with four Castors and four Adjusters. (See 6-2 Fig 01). Both consols are joined together via a central Coin/Credit consol making up the 'Twin' unit,.

Upto four Twin units may be coupled together for the Multi Player game,.
If several machines are to be installed, refer to Chapter 19.

1 Move the product to the installation point..
Move the cabinet with two or more people, as injury may occur.

2 Place both game consols side by side and attach them together using the 'Central Coin/Credit' column.
Make sure that the Game consols are handed correctly, Left hand Consol has a decal on the Left side check.
Right hand Consol, has a decal on the Right side check.

3 Place all cabinet adjusters in contact with the floor. Use a wrench to set adjuster heights so that the unit will remain level

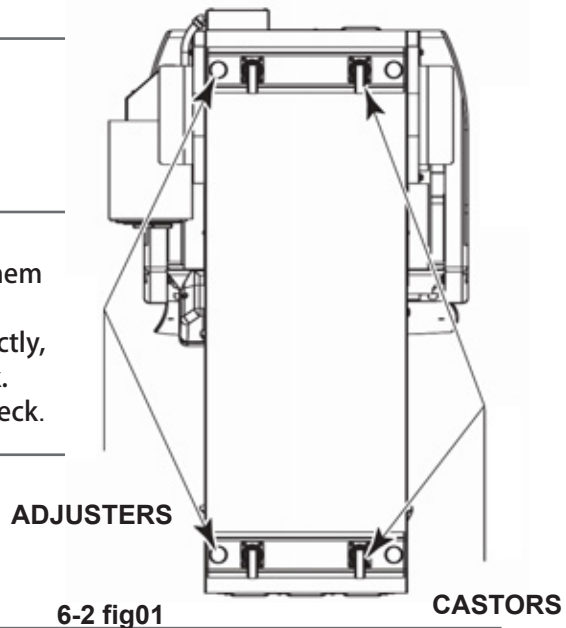

4 After setting the adjusters, screw all locking nuts upward until tight, to lock the adjuster heights.

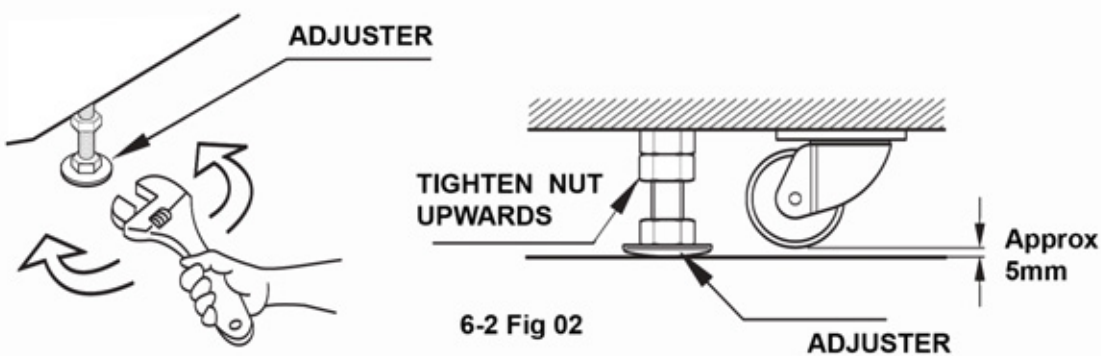

⚠ WARNING

Make sure that all the adjusters contact the floor.
Otherwise the cabinet could move, causing an accident.

6-2 ATTACHING THE DVD DRIVE AND KEY CHIP

PLEASE NOTE: The software is already loaded on to LINDBERGH and the KEY CHIP fitted at the factory. IF there is a problem with the software or LINDBERGH, then the following information is provided to re-load software on to replaced LINDBERGH. ADVD drive is available from STS.

- 1 Remove the two 'TRUSS SCREWS' , one from each side of the Lid.
- 2 Unlock the 'BASE' with the 'MASTER KEY' .
- 3 Turn the 'LOCK HANDLE, to the right to unlock the Lid..
- 4 Carefully lift up the LID and swing it over, gently lowering the back of the 'Drivers Seat' down onto the floor. Before doing this place a piece of cloth onto the floor where the back of the 'Driver Seat' will touch, to prevent 'Damage' to the 'Seat Back' . (See 6-3 Fig 06)

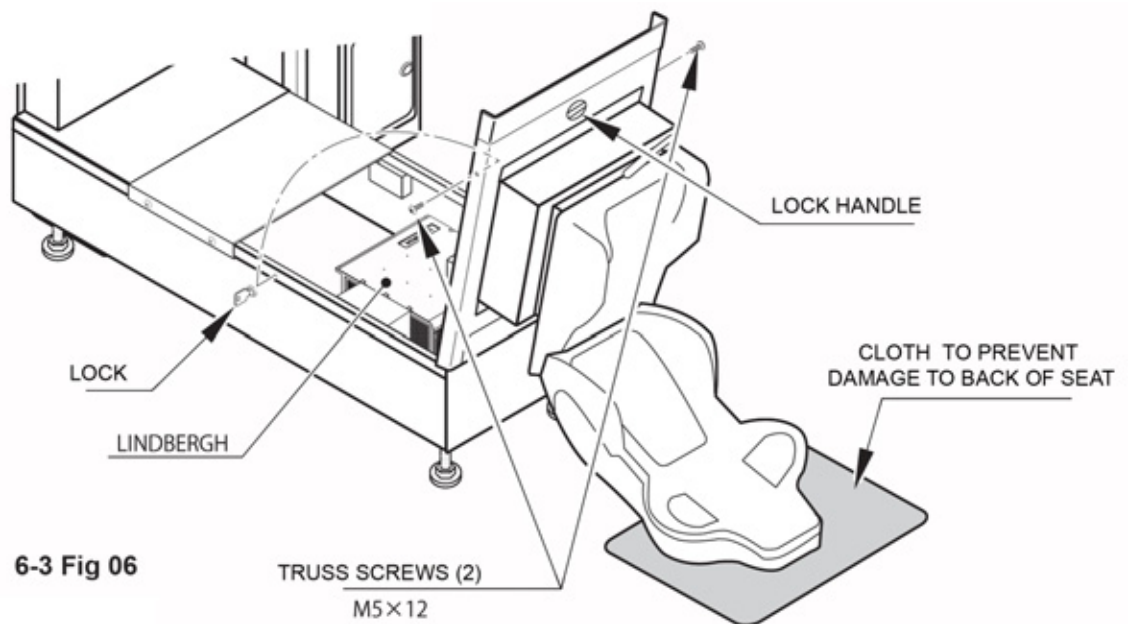

- 5 Remove the 'KEY CHIP' from the 'DVD' Software Kit, and insert the Key Chip into the 'LINDBERGH' . At this point, make sure to insert the Key Chip in the right direction and pushed all of the way in. At this time also attach the 'IDENTITY STICKER' to the Lindburg. (See 6-3 Fig 07)

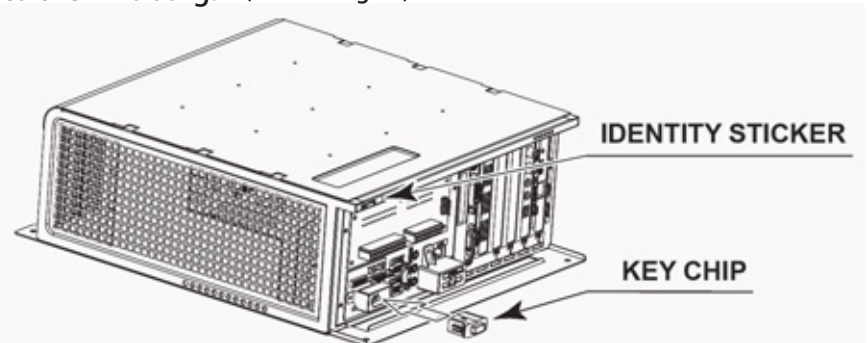

6-2 ATTACHING THE DVD DRIVE AND KEY CHIP

- 6 Connect the DVD Wire (2 Metres) to the LINDBURGH connect the connector on the side with the LINDBURGH tag. The 'USB MINI A' can be connected to any of th ports 1 - 4, This manual shows ig being connected to Port #1. (See 6-3 Fig 08)

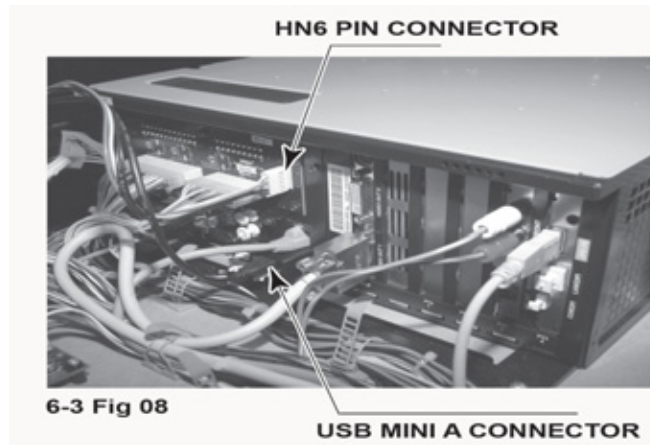

- 7 Take the other end of the DVD wire (2m) the end with the DVD tag and pass Pass it out through the cabel entry hole.
- 8 Pull the cabel out through the hole and connect it to the DVD Drive.
- 9 Pass the DVD wire (2m) through the edge holder (the rectangular frame-shape plastic part). Pressing down on the edge holder from above will make it stretch elastically and open up.
- 10 Re-attach the lower back lid, and fasten it with the six screws removed earlier.
- 11 Close the lid and fasten the seat in its original position, refer to steps 4 - 7 and work them in reverse order.

6-3 CONNECTION OF POWER AND GROUND

⚠ WARNING

- Use the power supply equipped with an earth leakage breaker. Use of power supply without such a breaker could result in fire if there is a current leakage.
- This product **MUST** be EARTHED. Ensure that the unit is properly connected to the INDOOR GROUND. Without proper grounding, customers could be electrocuted, product operation may not always be stable, and also introducing a risk of fire.
- Do not expose the power cords. If these are exposed, customers could stumble over them, for instance, and easily damage them. Additionally, if these lines are damaged, there could be a risk of electrical shock or short circuit. Set these lines at locations where they will not interfere with customer traffic, or attach covers to them.
- After laying out the power cord on the floor, be sure to always protect it. If the power cord is left exposed, it can easily be damaged, resulting in electrical shock.
- This product comes complete with POWER CORDS for the UK and EUROPEAN destinations, be sure to use the power cords supplied. If a power cord is to be replaced, be sure to replace it with the same specification as the one provided.

STOP IMPORTANT

If grounding has been established with the ground wire inside the power cord, do not perform grounding with the AC unit ground terminal. Conversely, if the AC unit ground terminal has been used for grounding, do not establish ground with the ground wire in the power cord. Otherwise there could be faulty or erroneous operations.

When using the product's AC Ground Terminal, use a ground wire with a circular terminal as shown in the illustration, and establish the ground securely. Avoid indiscriminate grounding operations such as the use of a wire with only the sleeve peeled off.

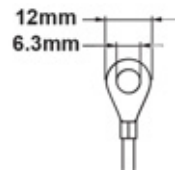

1 Confirm that the MAINS SWITCH is set to OFF

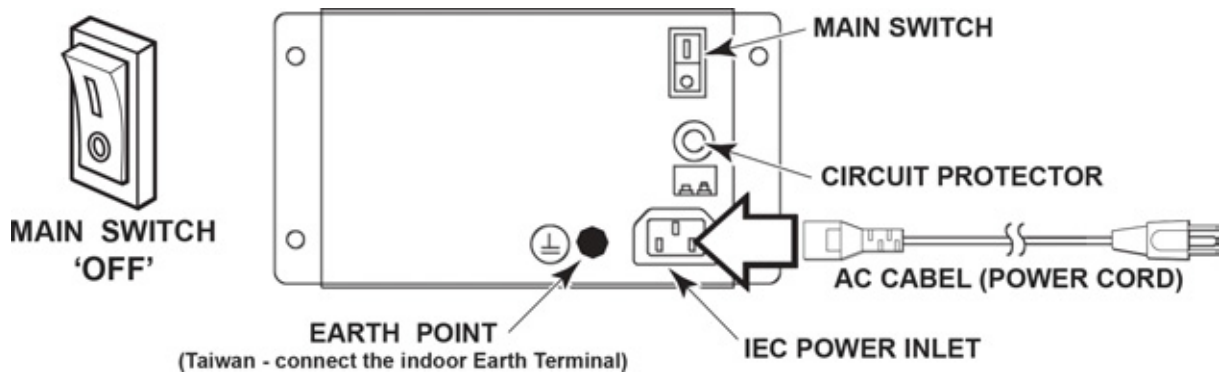

6-4 Fig02

6-3 CONNECTION OF POWER AND GROUND

- 2** The accessory power cord has a ground wire inside it. Connect the power cord to the AC unit then insert the power cord plug into a "power outlet with ground terminal." If there is no "power outlet with ground terminal," be sure to establish ground by some other means; for example, by connecting the AC unit ground terminal to a ground wire with a ground mechanism prepared separately.
If you use a conversion adapter sold on the market to supply power, connect the ground wire terminal of the adapter to a "securely grounded ground terminal." <For Taiwan>

(For TAIWAN)

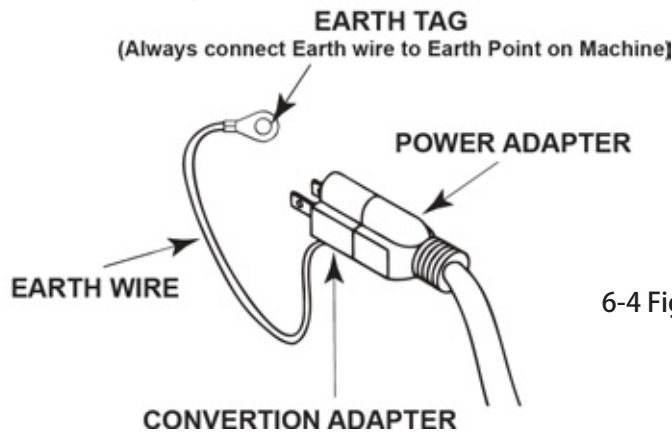

6-4 Fig 03

- 3** When using a ground wire made available separately, connect one end of the wire to the AC unit ground terminal and the opposite end to an indoor ground terminal. The AC unit ground terminal is a bolt-and-nut combination. Remove the nut and pass the bolt through the ground terminal, then secure the nut to the bolt.
<For Taiwan>

6-4 Fig 04

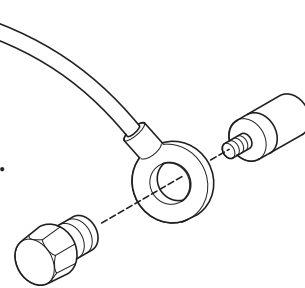

- 4** The power cord is laid out indoors. Protect the power cord by attaching wire cover to it.
If ground will be established with a ground wire made available separately, lay out the ground wire indoors and have it protected. <Taiwan>

6-4 Fig 05

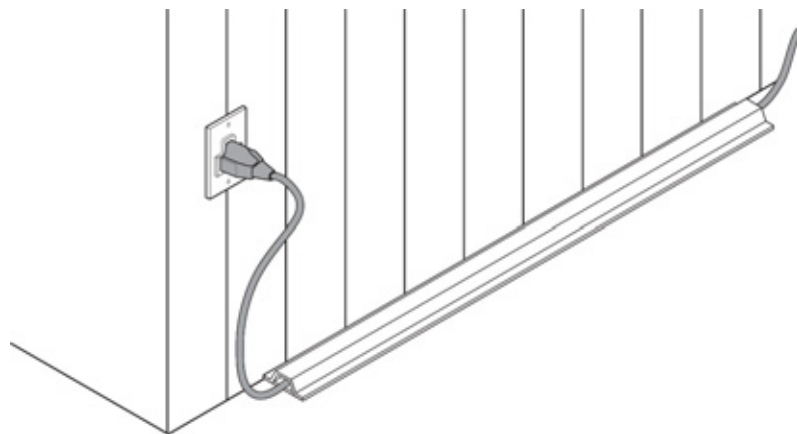

6-4 TURNING POWER ON - SOFTWARE INSTALLATION

WARNING

- Be careful not to damage the DVD wire by getting it caught between objects, etc. Doing so may cause a short circuit or fire.
- The following explanation assumes that the product has been assembled properly as explained above. If there is an error or if the product operates in a manner other than as indicated below, cut off the power supply immediately. Failure to do so may result in a fire or electrical shock.
- If you look directly at the laser beam in the DVD DRIVE, you could suffer vision impairment. Do not look inside the DVD DRIVE.

IMPORTANT

- Do not use or store the DVD Drive or DVD Wire in any of the following locations, as this may result in serious damage.
 - Anywhere which may vibrate or shock the equipment.
 - In direct sunlight.
 - In damp or dusty places.
 - In places with a sharp change in temperature.
 - Close to anything that gives off heat. (heater etc.)
 - Close to anything with a strong magnetic field. (magnets, monitors, speakers radio, etc)
 - Anywhere that is likely to get wet.
 - Anywhere with a slope or incline.
 - Anywhere with corrosive in the air. (chlorine, hydrogen sulfide, ammonia, sulphur dioxide etc)
 - Anywhere with strong static electricity.
- [Do not use in these locations]
 - Close to anything that is highly retentive of heat. (carpets, sponge, cardboard, etc.)
 - Anywhere that blocks the DVD air vent.
- The DVD is a delicate piece of equipment. Avoid the following.
 - Dropping or shaking it violently,
 - Getting water or liquids on top of it.
 - Placing small or large items on top of it
 - Drinking or smoking close to the DVD Drive.
- Do not turn off the power to the DVD when its Access Lamp is on or flashing, as this could cause damage to the device.
- Do not allow any foreign objects, such as liquids, metals, or smoke inside the DVD drive.

STOP IMPORTANT

- Use a soft dry cloth to wipe off any dirt or marks on the DVD Drive.
 - If you need to use a cleaning agent, always use a "neutral" agent diluted in water.
 - Never use products or cleaning agent containing benzene, alcohol, thinners, etc.
- Do not touch the LENS inside the DVD Drive. Doing so may prevent it from reading accurately.
- The chip components on the IC board can be damaged by electrostatic discharge from the human body, before handling an IC board always neutralize any static charge in the body by touching grounded metal surface.
- Some parts are not designed and manufactured specifically for the Software Kit. Manufacturers may discontinue, or change the specification of such general purpose parts. In which case, SEGA cannot repair or replace a failed component whether or not the warranty period has expired.

HANDLING THE DVD-ROM DISC

STOP IMPORTANT

- Do not use a DVD with a damaged Face. This may cause a malfunction.
- Insert the DVD ROM into the DVD Drive with the label facing upwards.
- Do not get finger prints or dust particles on the disc. Contaminated discs may lower audio and video quality, and may result in read malfunctions.
- When cleaning the disc, do not use volatile chemicals (benzene, thinners, cleaning sprays, or antistatic agents, etc.).
- Do not use a cracked, warped, or damaged disc.
- Do not attach papers or seals onto the disc to avoid scratching it.
- Do not use a disc with signs of peeled seals, tape, etc
- If such a disc is placed in the DVD ROM Drive, malfunctions, such as the inability to remove the disc from the drive, may result.
- When cleaning a contaminated disc, use a soft cloth that has been soaked in water and squeezed. After wiping, remove any remaining moisture with a clean dry cloth.
(See 6-5 Fig 01)
- When handling a Disc be careful not to contaminate it with your fingerprints.

HANDLING THE DISC

- 1 • To clean a disc, wipe it with a soft cloth, from the centre outwards.



6-5 Fig 01

- 2 • When handling a disc, using both hands, put your thumbs and forefingers on the opposite sides of the disc.



6-5 Fig 02

- 3 • Placing the DVD ROM into the DVD Drive, with one hand, put your forefinger into the centre hole while placing your thumb and middle finger on opposite sides of the disc. When inserting a DVD ROM into the Drive make sure that the label is facing upwards.



6-5 Fig 03

STOP IMPORTANT

- The software is not installed on the game board (LINDBERGH RED) when the power supply is engaged, so the "Error 22" message is not a malfunction.
However, if there is another error display, or if there is no video output at all, there might have been an error in product assembly, wiring connections might be faulty, or the LINDBERGH RED might not be functioning properly.
- After the power supply is engaged, wait for "Error 22" message to be displayed. If the product is indiscriminately operated in any way beforehand, there could be unexpected problems or malfunctions, as well as damage to parts.
- Once "Error 22" is displayed, set the DVD-ROM in the DVD DRIVE and re-engage the power supply. Installation takes place.
- After the power supply is engaged, the DVD DRIVE tray will not come out for about 30 seconds even if you press the switch. This is due to DVD DRIVE initialization.
- The DVD DRIVE tray can come out or return only while the power supply is engaged. The tray cannot be opened or closed while the power is off.
- Even after the software has been installed, store the DVD software kit, DVD DRIVE and DVD wire in a secure location.
- If for any reason installation cannot be completed, an error is displayed. Refer to the service manual and take corrective action.

SOFTWARE INSTALLATION

Take out the DVD Software Kit provided.

-
- 1** • Switch ON the MAIN POWER Switch on the AC Unit.

-
- 2** • The LINDBURGH starts up and an image appears on the screen (However, this may take several minutes depending on the type of display used), then an ERROR will occur. Check that it is "ERROR 22" and proceed to the next operation. If it's not "ERROR 22" take corrective measures as indicated in the LINDBURGH Service Manual.

6-4 TURNING POWER ON - SOFTWARE INSTALLATION

- 3 • Remove 1 urea (Resin Head) Screw, and then remove the DVD Case.

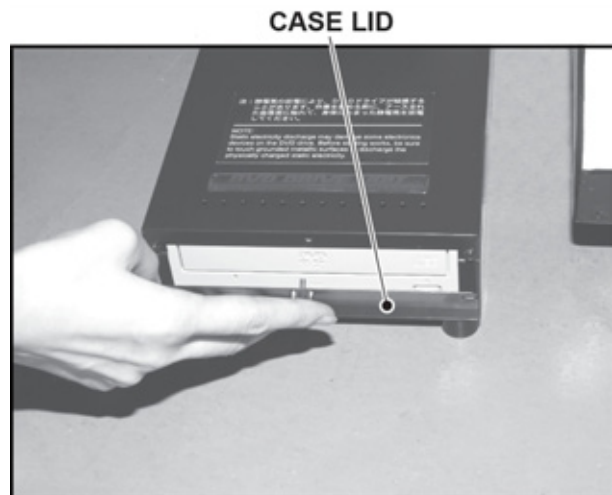

6-5 Fig 04

- 4 • Press the DVD Drive switch and the DVD Drive tray will open. Set the DVD ROM from the DVD Software Kit into the Tray. Always have the DVD label facing upwards.



6-5 Fig 05

- 5 • Press the DVD Drive switch and the DVD Drive tray will close

- 6 • Reset Power, Turn the MAIN POWER Switch OFF, wait a while and then turn it back on again.

- 7 • The Software installs Automatically from the DVD ROM to the LINDBURGH, In some cases, it may take upto 30 minutes for the installation to the LINDBURGH to be complete.

6-4 TURNING POWER ON - SOFTWARE INSTALLATION

- 8** • After the software installation, the Game Image will appear automatically.

GAME IMAGE

6-5 Fig 06



- 9** • Press the DVD Drive switch to open the tray, and remove the DVD ROM.
- 10** • Press the DVD Drive switch again to close the tray, When the power is off, the tray can not be moved.
- 11** • Set the MAIN POWER Switch OFF'
- 12** • Remove the DVD Wire (2m) from the DVD DRIVE.
- 13** • Refer to steps 1-13 in "6-3 ATTACHING THE DVD DRIVE AND KEY CHIP" and follow the steps in reverse order to detach the DVD Wire (2m) from the cabinet.
- 14** • Attach thw DVD Drive case lid and fasten it with 1 urea (Resin Head) Screw. Store the DVD Drive and DVD Software Kit at a location where there is no dust or cigarette smoke.
- 15** • Turn ON the MAIN POWER Switch on the AC unit. When the Game Image appears, installation is complete. (See 6-5 Fig 06)

6-5 CHECKING ASSEMBLY - SET UP

The Installation 'TEST MODE' ensures that the assembly has been made correctly and the IC BD is satisfactory (refer to Chapter 9).

Refer to the LINDBERGH Service manual for details on "SYSTEM TEST MODE" and "Chapter 9-3. GAME TEST MODE" for details on the |Game Test.

1 • DISPLAY TEST

When the 'MONITOR TEST' is selected from the 'System Test Menu Screen' a screen to test the CRT Monitor will be displayed. Though the DISPLAY is pre-adjusted at the time of shipment from the factory, view the test screen to determine whether or not adjustment is necessary. If so refer to Chapter 9 and adjust the display.

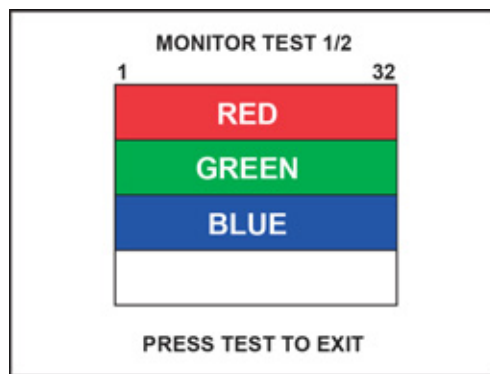

6-6 Fig 01

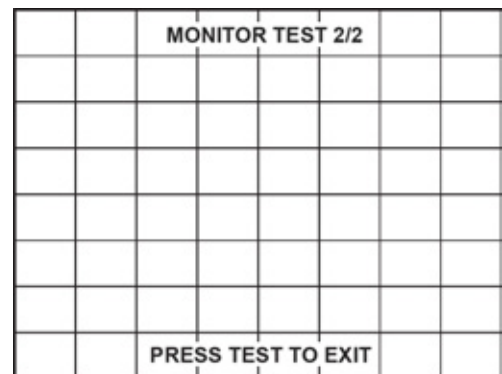

6-6 Fig 02

2 • INPUT TEST

When the 'INPUT TEST' is selected from the System Test Menu Screen' a screen to test the Games Switches will be displayed.

Flip each of the switches shown, if the display to the right of the switch changes to 'ON' or indicates a change in value, the switch and the wiring are operational.

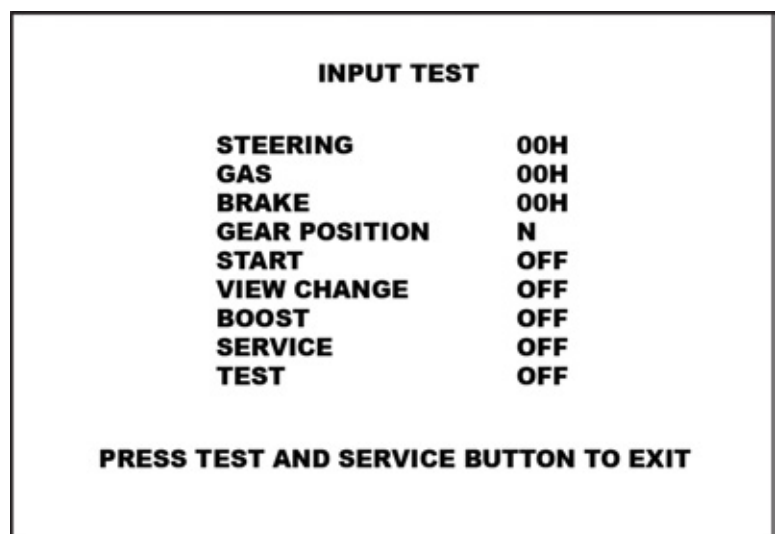

6-6 Fig 03

3 • OUTPUT TEST

When the 'OUTPUT TEST' is selected from the Sytem Test Menu Screen' a screen to test the Games Lamps will be displayed.

Use the SERVICE button to step to the output required to be checked and then press the Test Button.

If the output selected lights the lamp and wiring the Lamp and wiring are operational.

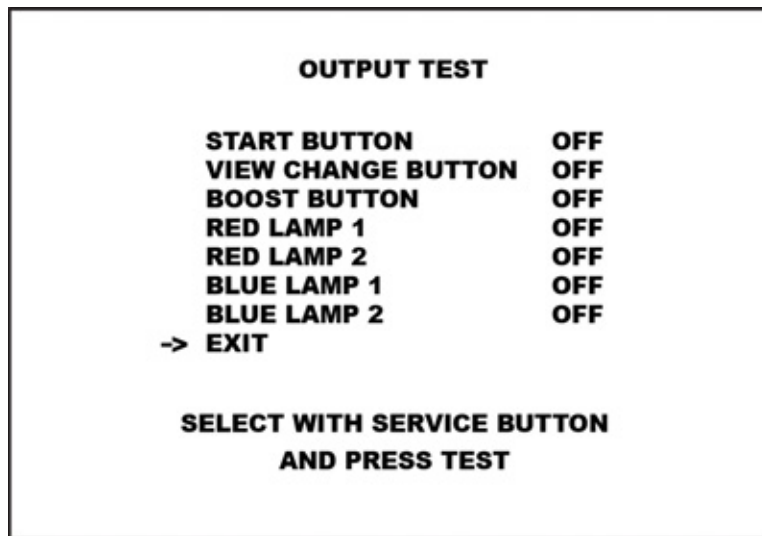

6-6 Fig 04

4 • SPEAKER TEST

When the 'SPEAKER TEST' is selected from the Sytem Test Menu Screen' a screen to test each of the Speakers will be displayed.

Use the SERVICE button to step to the speaker required to be checked and then press the Test Button.

The Right and Left Speakers are the only speakers that can be checked by just changing their respective settings to ON and OFF.

The WOOFER Speaker will only output sound when sound from both Right and Left speakers is played at the same time. No sound will be outputted by just changing its own setting to ON.



6-6 Fig 05

PERFORM THE ABOVE INSTALLATION TEST INSPECTIONS EVERY MONTH

SETTINGS AT TIME OF INSTALLATION

STOP IMPORTANT

During the initial Set Up Procedure, use the GAME TEST MODE to set the Seat Numbers' for the Cabinet and perform the settings for In-House Match-Ups.

Refer to the "LINDBURGH Service Manual" for details on the "SYSTEM TEST MODE" and "Chapter 9-3 GAME TEST" for the "GAME TEST MODE."

Using "TEST MODE" Set, Adjust and Confirm the following settings shown below.

1 • COIN ASSIGNMENTS

Set up the Coin Settings under - COIN ASSIGNMENTS

COIN CHUTE TYPE	-	COMMON
SERVICE TYPE	-	COMMON

2 • NETWORK SETTING

Select the MAIN NETWORK and set it up in the following manner:

DHCP	-	DISABLE
------	---	---------

There is no need to set a specific value for the IP address. Leave the display IP address as is and exit the settings.

7 PRECAUTIONS WHEN MOVING THE MACHINE

⚠ WARNING

- Always disconnect the power cable before moving the product. If it is moved with the power cable connected, the cable could be damaged, causing fire or electric shock.
- Do not push the cabinet from the left/right when attempting to move the unit. Pushing from the sides may cause the unit to tip and result in injury and damage to parts.

⚠ CAUTION

Do not push on any parts made of glass (e. g. CRT screen) or plastic, as these parts may break and result in bodily injury.

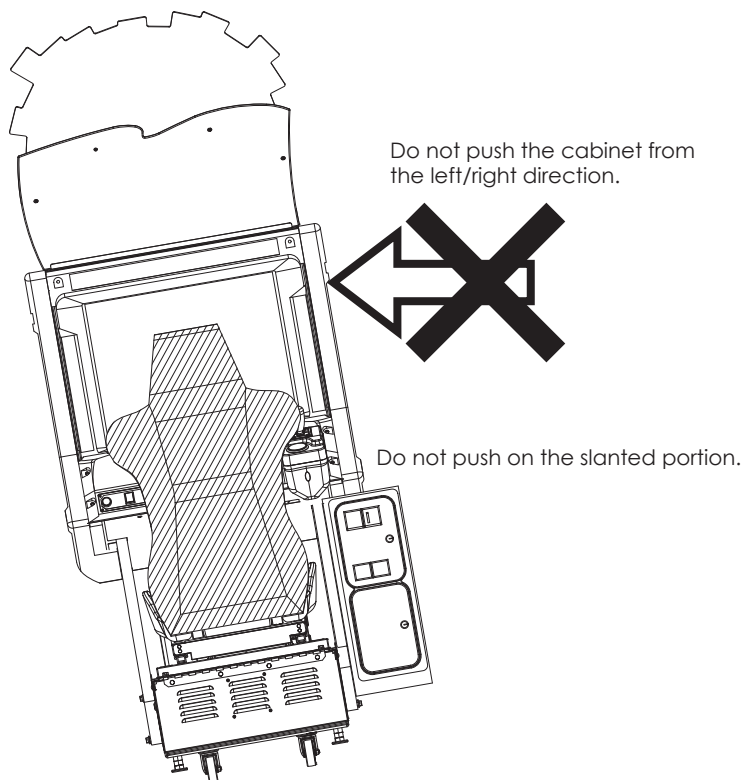

7 FIG. 01

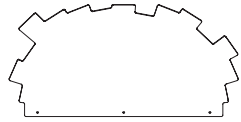

In locations with low ceilings,
remove the POP and POP Holder
before moving the machine.

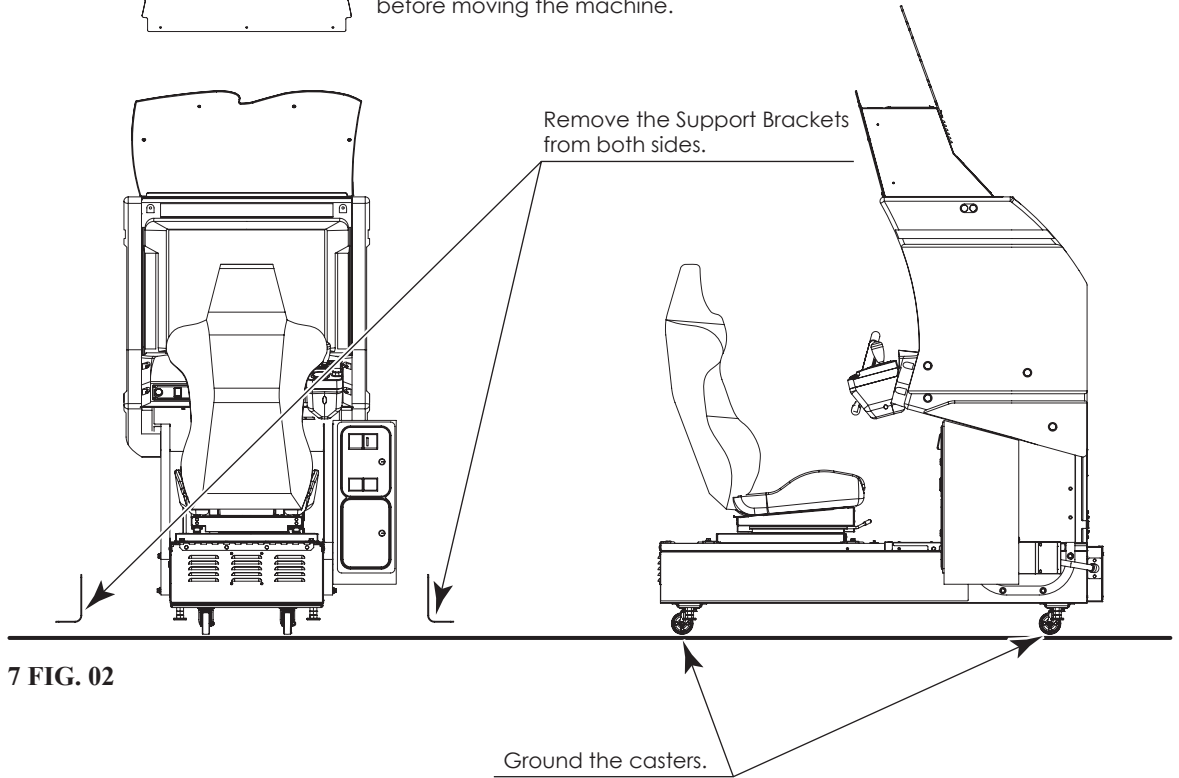

7 FIG. 02

8 GAME DESCRIPTION

The following explanations apply when the product is functioning satisfactory. Should there be any actions different from the following contents, some sort of fault may have occurred. Immediately look into the cause of the fault and eliminate the cause thereof to ensure satisfactory operation.

8-1 GAME OVERVIEW

This 'CAR Racing' game has two modes of operation :
Players can select either a 'MULTIPLAYER' or 'SINGLE PLAYER' Game, plus their choice of CAR, DRIVER and COURSE,

A wide variety of real time action, based on players actions make the race more exciting.

Pushing the 'BOOST' button will make their car rapidly accelerate.

Players can also dress up their cars by entering a Password, once they have been given one.

1 Choice of CAR (in alphabetical order)

CHEVROLET (R)	CAMARO (R) Concept Convertable
	CORVETTE (R) Stingray (TM) Convertable
CHRYSLER (R)	Prowler (TM)
FORD	Mustang GT Convertable
MAZDA	Roadster RS
MERCURY	1949 Convertable (Time Release (See 8-5))
MITSUBISHI	Eclipse Spyder GT
PLYMOUTH	Hemi (R) Cuda Convertable
RUF	R K Spyder

2 Choice of DRIVER

SELECTING A DIFFERENT DRIVER WILL CHANGE THE COLOUR OF YOUR CAR

8-1 GAME OVERVIEW

There are initially four COURSES available to select from with a fifth course being automatically added on a 'Time Release'. All courses are based on laps, and can be set to either 3 or 4.

3 Choice of COURSE (RACE TRACK)

COURSE	LAPS	TIME OF DAY
JAKE' S WORK	Counter Clockwise	Day
SLIP CIRCUIT	Counter Clockwise	Night
SUNSHINE COAST	Counter Clockwise	Day
RUMBLING VOLCANO	Clockwise	Evening
RTV ARENA *	Counter Clockwise	Evening

* Time Release (See 8-5)

RACE SCREEN



1 ADVERTISEMENT DISPLAY

Insert Coins until you have enough credits to play the game at which point the 'Credit' button on the machine will light.

Pressing the Credit button will then transfer credit to your screen and the game will start automatically.

A message will be displayed prompting you to insert additional coins if you do not have enough credit.



8-2 Fig 01

2 Select GAME Screen

Select the GAME type to be played by turning the steering wheel left or right, lighting either the 'Multi Player' or 'Single Player' Panels and then peither ress the 'Pedal' or 'Start' button to confirm your selection'

If 'Communication Play' is not enabled, the 'Multi Player' option will be darkened and not be available for selection.



8-2 Fig 02

MULTI PLAYER - Play against other players for amusement only.

SINGLE PLAYER - Play to complete all three stage.

3 Select CAR Screen

Select your CAR by turning the steering wheel left or right, high-lighting each of the eight cars available to drive.

Move the shift lever up or down tand choose 'Automatic' or 'Manual' transmission.

Press either the 'Pedal' or 'Start' button to continue.

Push the VIEW CHANGE button to go to the PASS WORD screen.



8-2 Fig 03

4 Select DRIVER Screen

Select your DRIVER by turning the steering wheel left or right. The colour of the Car will automatically change depending on the driver selected.

Each driver has his or her own ending movie.

Press either the 'Pedal' or 'Start' button to continue.



8-2 Fig 05

5 Select COURSE Screen

Select your COURSE by turning the steering wheel left or right.

When playing the 'Multiplayer Games' the Course is selected by popular vote. If there is a draw, the earliest selected course will be used.



8-2 Fig 05

6 CONTINUE Screen

In SINGLE PLAYER mode, you will be given the option to continue if you do not finish the race within the Regulation Finishing place.

Providing you have enough credit you can select 'YES' and play the course again.

If you continue playing a course at Stage 'One' or 'Two', the Regulation Finishing place for moving onto the next stage is increased by one, upto a maximum of five places. During the final stage, in order to win no matter how many times you Continue, you must achieve Place ONE



8-2 Fig 06

7 CUSTOM CAR Screen

In the 'SINGLE PLAYER' game mode you will be issued a PASSWORD the first time you complete all 3 Stages.



8-2 Fig 07

NOTE : Passwords are not issued during 'Multi Player' games.

8 NAME ENTRY Screen

In the 'SINGLE PLAYER' game mode you will be able to enter your name (up to three characters) if you make it into the top ranks within the total time required to complete the course you were competing in.

Your name will be displayed in the Ranking during the Advertisement Display (8-2 Fig 01).



8-2 Fig 08

9 GAME OVER Screen

The GAME OVER Screen is displayed at the completion of every game.



8-2 Fig 09

8-3-1. MULTIPLAYER GAME

Game Content and Rules

In this mode, players on the machine in the same facility can compete against each other.

Up to four machines can be used for COMMUNICATION PLAY, giving a total number of eight players, if all players wish to play the Multiplayer Game.

The game lasts for one race, regardless of ranking, and no passwords are issued.

Once any player passes a checkpoint, extra time is awarded to all players.

The first player to cross the 'Finish Line' or the player in the 'First Position' when the time expires is declared the WINNER and the game is over.

If there is no competition players available the game will default to Single Player mode.

If a players wish to play a Multiplayer Game which is already in progress, they must wait to the start of the next game.

8-3-2. SINGLE PLAYER GAME

Game Content and Rules

In this mode, the player attempts to complete all three stages of the race, .

Players must compete against seven others CPU players and in order to continue onto the next stage, the player must achieve a position within the 'Regulation Finishing' place.

'REGULATION FINISHING' Places

Stage 1	THIRD Place of Higher.
Stage 2	SECOND Place of Higher
Stage 3	FIRST Place.

After a 'FIRST Place' finish in the Final Stage 3, the 'Ending Movie' will be played and a dress up Password will be issued. (If the dress up level is at MAX, no password will be issued.)

If the first stage is selected on the COURSE SELECT screen, any remaining stages of the race, will be selected automatically.

Passing a CHECK POINT will cause the 'Time Remaining' clock to increase.

The 'Time Remaining' at the end of any stage will be automatically added to the the time allowance for the next stage.

8-4 PASSWORD CONDITIONS

In SINGLE GAME mode, if any of the following conditions are met, the player will be issued with a PASSWORD after the game is finished.

- A. The player completes the game without any dressing up, regardless of whether a stage was cleared or not.
- B. The dress up level is not at MAX and all three stages have been completed.

A password consists of four letters and include the following information :

- A. CAR
- B. DRIVER (Colour of Car)
- C. AT/MT (Automatic or Manual Transmission)
- D. DRESS UP LEVEL (Indicated by Number of Stars)

The 'Dress Up Cars' can be used in MULTIPLAYER or SINGLE PLAYER mode by entering the PASSWORD during the CAR Selection.



8-4 Fig 01

NOTE : There are also special passwords that are not issued for regular games. These passwords are planned to be introduced one by one on the official website.

8-5 TIME RELEASE

When the power is turned ON after the Date designated in the machines built in Calendar, the following will be added to the available options :

A	CAR	Mercury - 1949 Convertable
B	DRIVER	Jake Paterson
C	COURSE	RTV - ARENA

Passwords for the newly available Car and Driver will become active, and the Ranking for the newly added Course will be displayed in the Advertisement loop.

For a period of one month after the Time Release, an announcement will be displayed in the advertisement demo (See 8-5 Fig 01), and an icon reading NEW will be displayed next to the applicable item' (See 8-5 Fig 02),



8-5 Fig 01

8-5 Fig 03



8-5 Fig 02

9 TEST MODE

Perform periodic tests and data checks using the TEST and SERVICE buttons inside the cabinet. Follow the instructions in this chapter to conduct checks when the game machine is first installed, when money is being collected, or when the game machine does not operate properly.

Shown below are the tests and screens to be used for different problems.

This product uses a LINDBERGH game board and a DVD DRIVE. In the system, a different game can be played by putting a different DVD ROM in the DVD DRIVE.

For this reason, the product's Test Mode consists of two modes: a System Test Mode for systems in which coin settings, for instance, are made for products that use the same system, and the Game Test Mode for setting of difficulty level, etc., and for input/output test of operational units used exclusively with this product.

9 TABLE 01 EXPLANATION OF TEST MODE

ITEMS	DESCRIPTION	REFERENCE SECTIONS
INSTALLATION OF MACHINE	<ol style="list-style-type: none"> 1. Check to ensure each is the standard setting at shipment. 2. Check each Input equipment in the INPUT TEST mode. 3. Check each Output equipment in the OUTPUT TEST mode. 	<p>S/M Chapter 4</p> <p>S/M Chapter 4, 6-6, 9-3-2, 9-3-5</p> <p>S/M Chapter 4, 6-6, 9-3-3</p>
PERIODIC SERVICING	<p>Periodically perform the following:</p> <ol style="list-style-type: none"> 1. Ascertain each setting. 2. To test each Input equipment in the INPUT TEST mode. 3. To test each Output equipment in the OUTPUT TEST mode. 	<p>S/M Chapter 4, 6-6, 9-3-4, 9-3-5, 9-3-6</p> <p>S/M Chapter 4, 6-6, 9-3-2, 9-3-5</p> <p>S/M Chapter 4, 6-6, 9-3-3</p>
CONTROL SYSTEM	<ol style="list-style-type: none"> 1. To check each Input equipment in the INPUT TEST mode. 2. Adjust or replace each Input equipment. 	<p>S/M Chapter 4, 6-6, 9-3-2, 9-3-5</p> <p>Chapter 10, 11, 12</p>
MONITOR	In the Monitor Adjustment mode, check to see if Monitor (Projector) adjustments are appropriate.	S/M Chapter 4, 6-6, 14
IC BOARD	<ol style="list-style-type: none"> 1. Information Display Screen 2. SPEAKER TEST 	<p>S/M Chapter 4</p> <p>S/M Chapter 4</p>
DATA CHECK	Check such data as game play time and histogram to adjust the difficulty level, etc.	9-3-7

NOTE: "S/M" in the table denotes LINDBERGH service manual, which is provided separately.

9-1 SWITCH UNIT AND COIN METER

⚠ WARNING

Never touch places other than those specified. Touching places not specified can cause electric shock and short circuit accidents.

⚠ CAUTION

Be careful that a finger or hand does not get caught when opening/closing the coin chute door.

STOP IMPORTANT

- When you enter the Test Mode, fractional coin and bonus adder data is erased.
- Adjust the sound to the optimum volume, taking into consideration the environmental requirements of the installation location.
- Removing the Coin Meter circuitry renders the game inoperable.

SWITCH UNIT

Open the coin chute door, and the switch unit shown will appear.
The functioning of each SW is as follows:

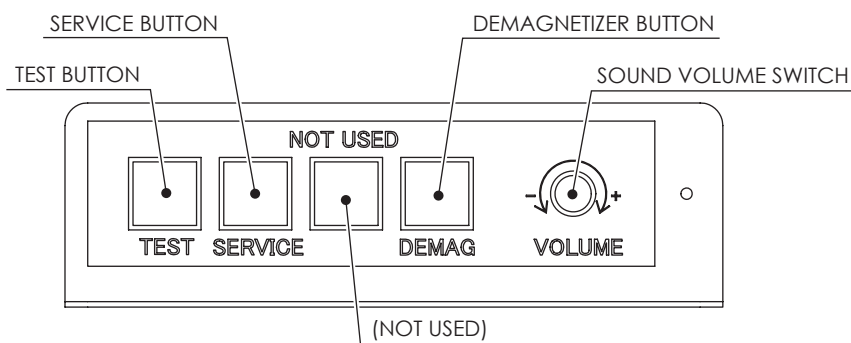

9-1 FIG. 01 SWITCH UNIT

- | | |
|-------------------------------|--|
| TEST BUTTON (TEST): | For the handling of the test button, refer to the following pages. |
| SERVICE BUTTON (SERVICE): | Gives credits without registering on the coin meter. |
| DEMAGNETIZER BUTTON (DEMAG): | Eliminates the on-screen color unevenness due to magnetization of CRT. First use this SW before performing the monitor's color adjustment. |
| SOUND VOLUME SWITCH (VOLUME): | Adjusts sound volume for all of the machines' speakers. |

COIN METER

Open the Cashbox Door by using the key to have the Coin Meter appear underneath the Cashbox.

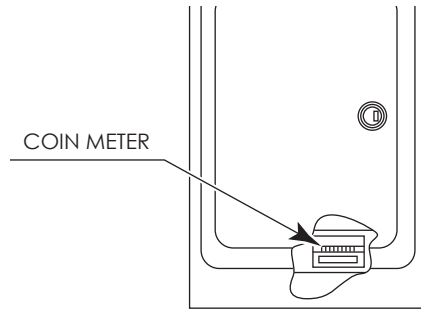

9-1 FIG. 02 COIN METER

9-2 SYSTEM TEST MODE

STOP IMPORTANT

- Refer to **BOOKKEEPING in GAME TEST MODE** for this product' s data.
- Adjust for an appropriate sound volume in consideration of the installation site.
- If the coin meter circuit is removed, play cannot be executed.
- Read the **LINDBERGH service manual** included with the product for details about **System Test Mode**. However, the settings for this product should follow the specifications in this manual.

In the SYSTEM TEST MODE, LINDBERGH board functioning can be checked, the monitor adjusted, and the coin setting performed. Refer to LINDBERGH service manual for the details.

Note that the settings of the following items need to be performed in accordance with the instruction given.

COIN ASSIGNMENTS

COIN CHUTE TYPE:	COMMON
SERVICE TYPE:	COMMON

NETWORK SETTING

MAIN NETWORK	
DHCP:	DISABLE

NOTE: An IP address will be shown, but there is no need to change it.

9-3 GAME TEST MODE

STOP IMPORTANT

- When changing the game configuration, changes will not take effect until the Game Test Mode properly after configuration changes. Be sure to exit the Game Test Mode properly after configuration changes.
- Do not configure the game in ways not described in this text. It is possible that the game will not function properly.

9-3-1 GAME TEST MODE Menu

Select GAME TEST MODE from the System Menu screen to display the Game Test Menu screen.

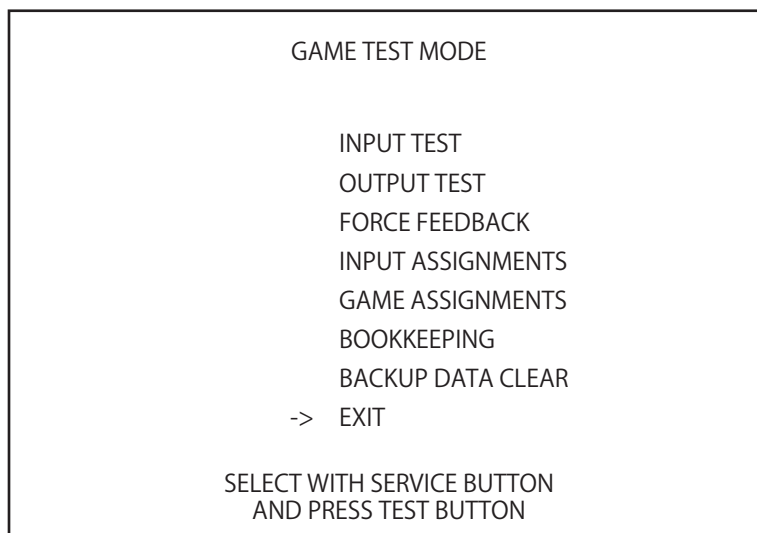

9-3-1 FIG. 01

Use the SERVICE Button to move the cursor to the desired test item.
Press the TEST Button to enter the selected item.

9-3-2	INPUT TEST:	Test each input
9-3-3	OUTPUT TEST:	Test each output
9-3-4	FORCE FEEDBACK:	Set the STEERING resistance
9-3-5	INPUT ASSIGNMENTS:	Adjust input settings
9-3-6	GAME ASSIGNMENTS :	Adjust game settings
9-3-7	BOOKKEEPING:	View game backup data
9-3-8	BACKUP DATA CLEAR:	Clear game backup data
	EXIT:	Go back to the System Test Menu

Move the cursor to EXIT and press the TEST Button to return to the System Menu screen.

9-3-2 INPUT TEST

Select INPUT TEST to display the following screen and check the status of input devices. This test should be used periodically to check that each input device is functioning correctly.

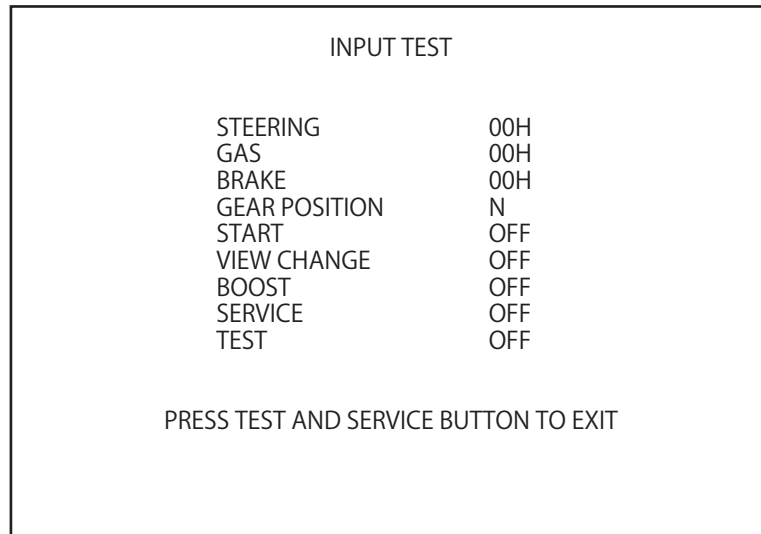

9-3-2 FIG. 01

Test the STEERING, GAS and BRAKE controls to ensure that they are functioning properly and that the parameters change smoothly as each input device is operated.

Display N, UP and DOWN using the GEAR POSITION. N should display there is no control input. Verify that both UP and DOWN display in sync with the position of the gear shifter.

Other controls are working properly if the OFF display changes to ON when operating the corresponding input device.

Press the SERVICE and TEST Buttons simultaneously to return to the Game Test Menu Screen.

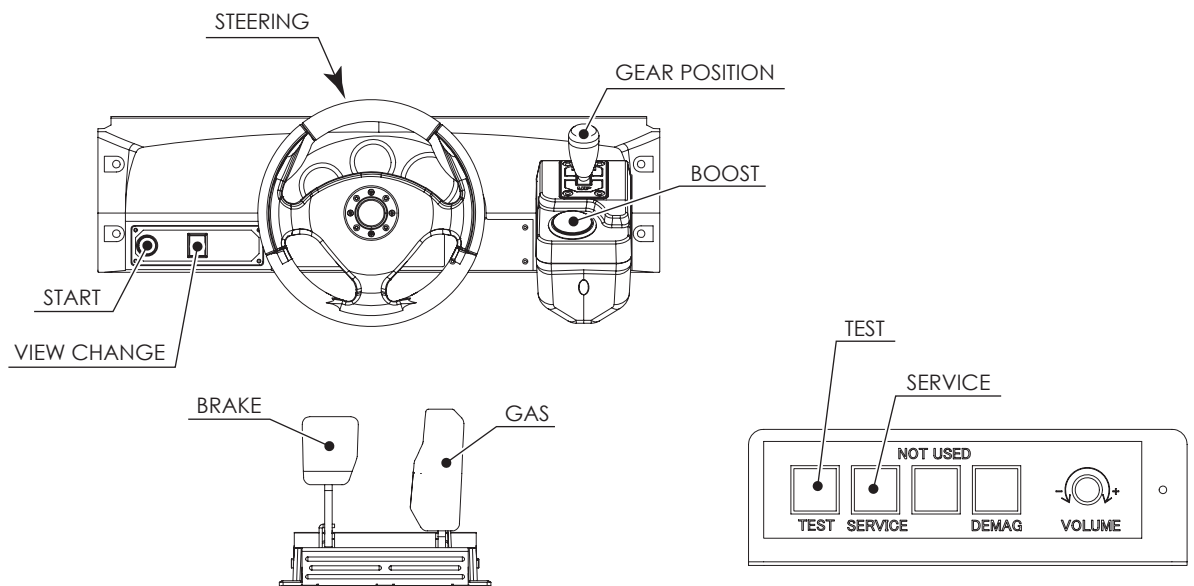

9-3-2 FIG. 02

9-3-3 OUTPUT TEST

Select OUTPUT TEST to display the following screen and check the status of each lamp.
This test should be used periodically to check that the lamps are functioning correctly.

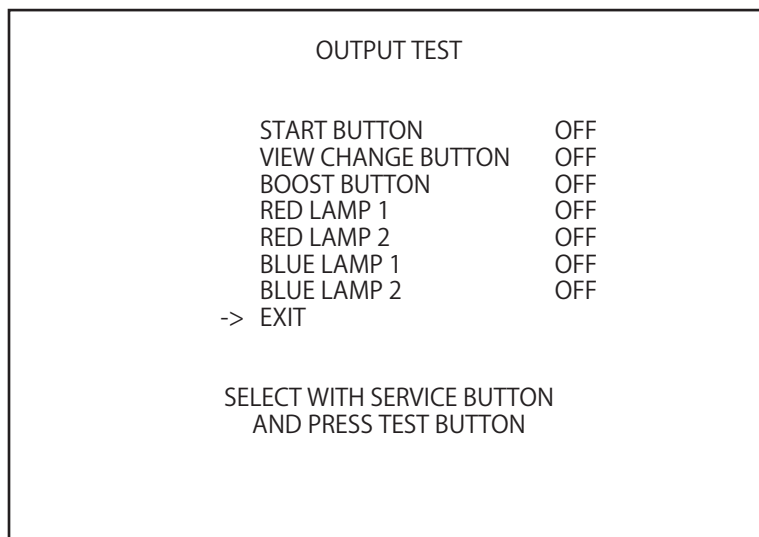

9-3-3 FIG. 01

If you press the TEST button after placing the arrow beside an item, the status will be switched to “ON,” and the corresponding button and lamp will come on. Pressing the TEST button again will switch the status back to “OFF,” and the lamp will go out.

BLUE LAMPS and RED LAMPS are inside the billboard box. Refer to 9-3-3 FIG. 02.

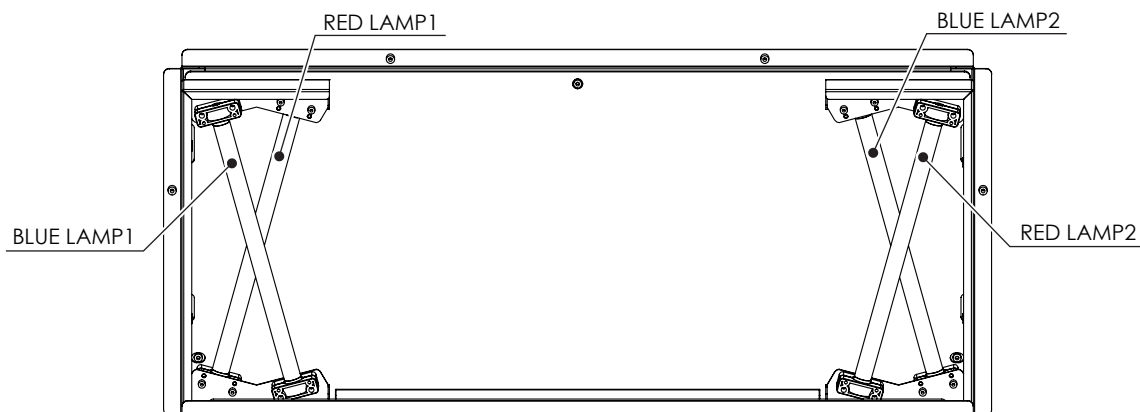

9-3-3 FIG. 02

Move the cursor to EXIT and press the TEST button to return to the Game Test Menu Screen.

9-3-4 FORCE FEEDBACK

CAUTION

When you select "FORCE FEEDBACK" , a connection test runs and the STEERING rotates. Make sure that no one is touching the STEERING before running these tests as contact may cause injury.

After the check is completed, the following FORCE FEEDBACK screen will appear, and you will be able to set the level of STEERING resistance.

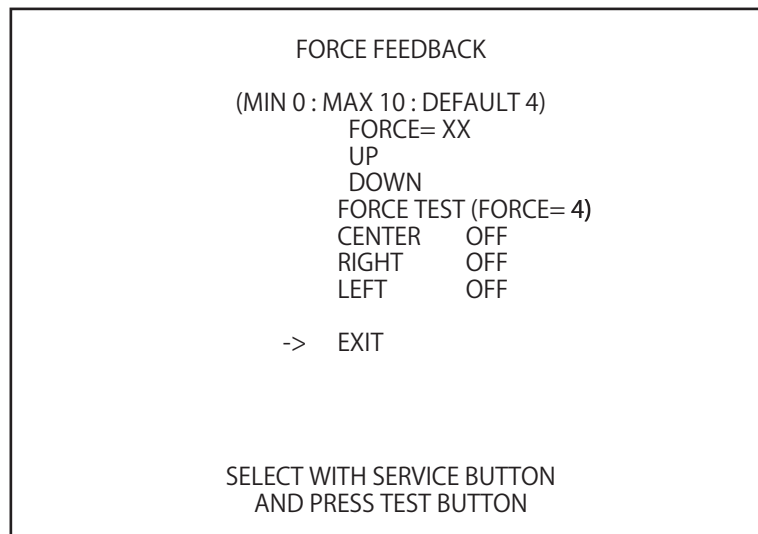

9-3-4 FIG. 01

- **FORCE:** Set the STEERING resistance. The ** indicates the current resistance setting. The smaller the value, the weaker the resistance; the larger the value, the stronger the resistance. (Minimum value is 0; the maximum value is 10. The default setting is 4.) Move the cursor to UP or DOWN and press the TEST Button to change the value.
- **FORCE TEST:** Verifies the STEERING motor is working properly. Toggle between OFF and ON by aligning to CENTER and pressing the TEST Button. The STEERING will rotate and stop in the center position. Pressing the SERVICE Button moves the cursor to the next menu item and CENTER changes to OFF. Control of the STEERING is then released. When the RIGHT menu item is ON, the STEERING rotates to the right as far as possible and then stops. Press the SERVICE Button again to turn it OFF and release control of the STEERING. When the LEFT menu item is ON, the STEERING rotates to the left as far as possible and then stops. Press the SERVICE Button again to turn it OFF and release control of the STEERING.

Move the cursor to EXIT and press the TEST Button to return to the Game Test Menu Screen.

9-3-5 INPUT ASSIGNMENTS

Select INPUT ASSIGNMENTS to display the following screen.

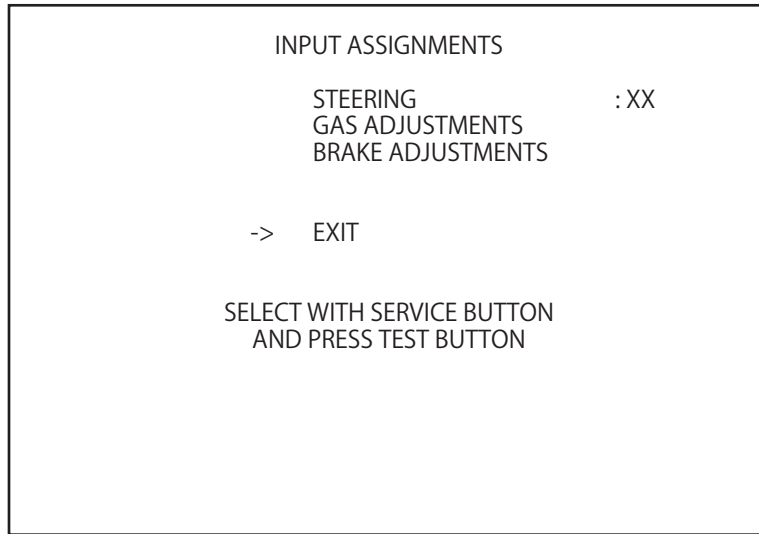

9-3-5 FIG. 01

- STEERING: Adjust the centering of the STEERING control.
- GAS PEDAL, BRAKE PEDAL: Adjust the GAS and BRAKE pedals.

Move the cursor to EXIT and press the TEST Button to return to the Game Test Menu Screen.

STEERING

Make adjustments to STEERING.
Press the TEST Button to display the following screen.

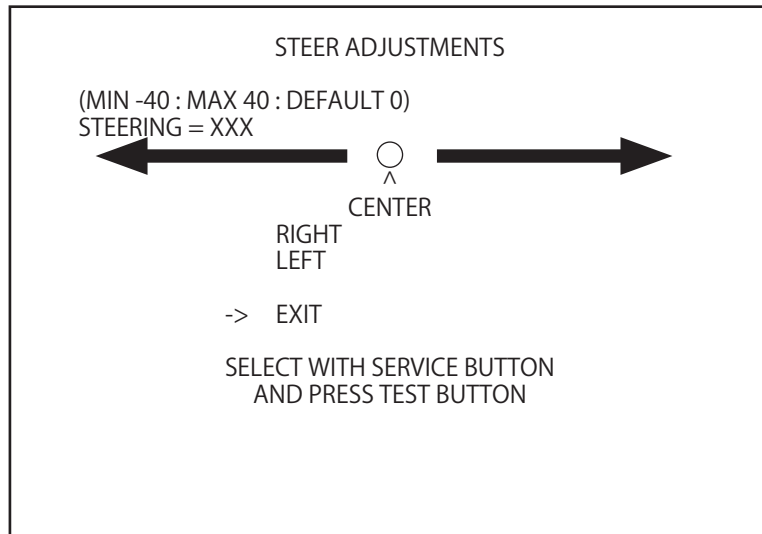

9-3-5 FIG. 02

Center the STEERING. When the "o" displayed is not exactly aligned with the "^" mark above CENTER, use the cursor to select RIGHT or LEFT and move the "o" until it is displayed directly above the "^" mark.

Move the cursor to RIGHT and press the TEST Button to move the "o" to the right. Each time you press the TEST Button, "o" moves slightly to the right.

Move the cursor to LEFT and press the TEST Button to move the "o" to the left. Each time you press the TEST Button, "o" moves slightly to the left.

Move the cursor to EXIT and press the TEST Button to return to the INPUT ASSIGNMENTS Screen.

GAS ADJUSTMENTS

Make adjustments to GAS.

Press the TEST Button to display the following screen.

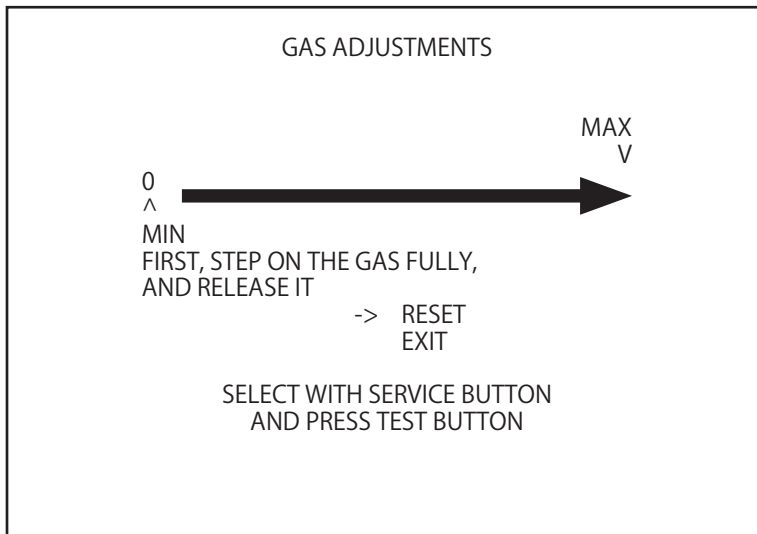

9-3-5 FIG. 03

Set the MAX position by stepping on the GAS pedal. The "MAX" display moves to the right depending on how hard the pedal is pressed.

Entering GAS ADJUSTMENTS without having the GAS pedal pressed down automatically sets the MIN position.

NOTE: If you enter GAS ADJUSTMENTS with the GAS pedal pressed down, set the MIN position by releasing the GAS pedal. The "MIN" display moves to the left depending on how much the pedal is released.

Move the cursor to RESET and press the TEST Button to reset MAX and MIN.

Move the cursor to EXIT and press the TEST Button to return to the INPUT ASSIGNMENTS Screen.

BRAKE ADJUSTMENTS

Make adjustments to BRAKE.

Press the TEST Button to display the following screen.

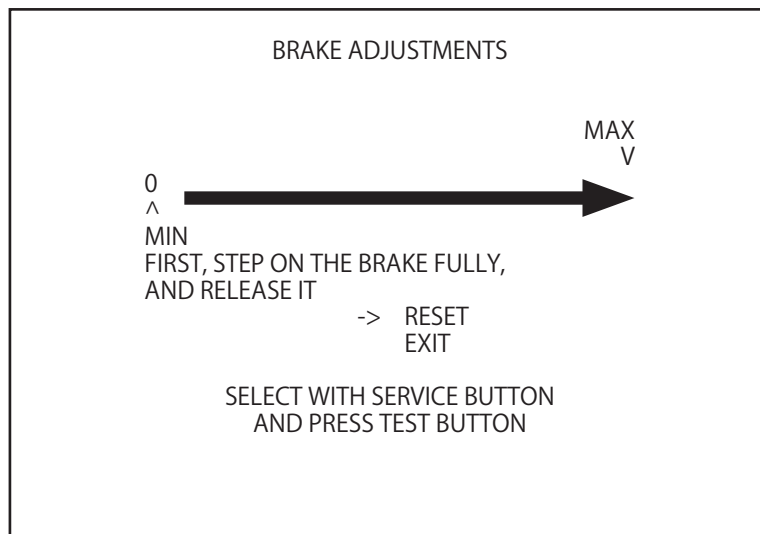

9-3-5 FIG. 04

Set the MAX position by stepping on the BRAKE pedal. The "MAX" display moves to the right depending on how hard the pedal is pressed.

Entering BRAKE ADJUSTMENTS without having the BRAKE pedal pressed down automatically sets the MIN position.

NOTE: If you enter BRAKE ADJUSTMENTS with the BRAKE pedal pressed down, set the MIN position by releasing the BRAKE pedal. The "MIN" display moves to the left depending on how much the pedal is released.

Move the cursor to RESET and press the TEST Button to reset MAX and MIN.

Move the cursor to EXIT and press the TEST Button to return to the INPUT ASSIGNMENTS Screen.

9-3-6 GAME ASSIGNMENTS

Select GAME ASSIGNMENTS to display the following screen.

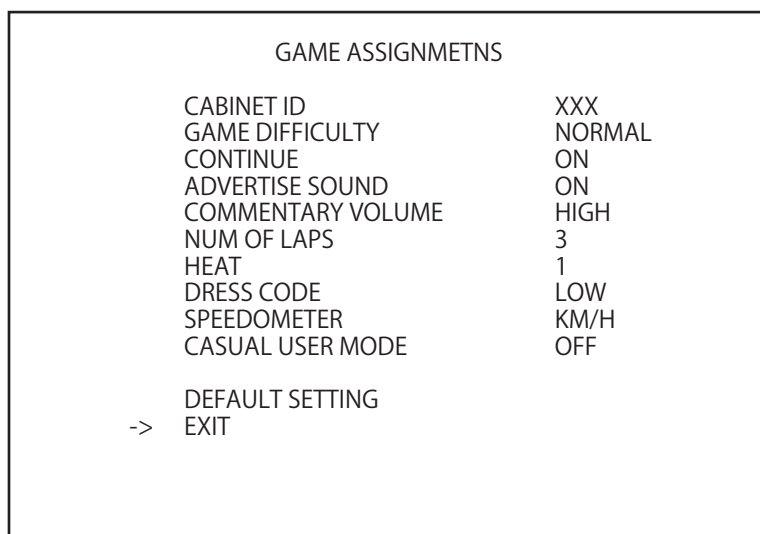

9-3-6 FIG. 01

- **CABINET ID:** This setting assigns a seat number to the cabinet for use in “Multi Player Game”. You may select one of the following settings: NO DEFINED, 1(MAIN), 2, 3 or 4. When setting up cabinets for Multi Player Game, assign each cabinet the number from “1”. (Make sure they are not assigned the same number). Set to NO DEFINED if you do not need to set the cabinet up for Multi Player Game. During COMMUNICATION PLAY, the difficulty level and other settings will be taken from the game machine with the CABINET ID of “1.” When changes are made to settings on a machine other than CABINET ID “1”, that machine will follow those settings.
- **GAME DIFFICULTY:** Set the level of difficulty for the game. You may select one of 3 different levels of difficulty: EASY, NORMAL, HARD.
- **CONTINUE:** Enable/Disable Continue function.
 ON: Enables Continue.
 OFF: Disable Continue.
- **ADVERTISE SOUND:** Turn sound on the Advertise Screen on and off.
 ON: Sound is played on the Advertise Screen.
 OFF: Sound is not played on the Advertise Screen (except when inserting coins).
- **COMMENTARY VOLUME:** Adjust the volume for the race commentary. You may select one of the 3 levels of difficulty: LOW, NORMAL, HIGH.
- **NUM OF LAPS:** Set the number of laps.
 3, 4: Indicates the number of laps.
- **HEAT:** Set the assistance level for COMMUNICATION PLAY.
 0, 1, 2: A setting of “0” gives no assistance, while a setting of “2” provides maximum assistance.

- DRESS CODE: Switches the level of female appearances in the game.
 - LOW: All screens and movies will be displayed.
 - HIGH: The advertise movie will be cut.
Driver selection will be cut.
(Player will not be able to select car and driver.)
The ending movie will be cut.

- SPEEDOMETER: Set the SPEEDOMETER display.
 - KM/H: Shows the speed in kilometers per hour.
 - MPH: Shows the speed in miles per hour.

- CASUAL USER MODE: Set the difficulty level of vehicle handling.
 - OFF: Normal level.
 - ON: Level of difficulty adjusted for casual users.
 - The turn performance and ease of drifting are increased.
 - The game will provide extra assistance to prevent vehicle control loss.
 - The CPU vehicles' performances are adjusted.
 - The BOOST GAUGE will be full when the race begins.
 - When AT is selected, the gears will not respond to the shift lever.
 - 5 seconds are added to the wait time.

- DEFAULT SETTING: Returns all items under GAME ASSIGNMENTS to their default values.

Move the cursor to EXIT and press the TEST Button to return to the Game Test Menu Screen.

9-3-7 BOOKKEEPING

Select BOOKKEEPING to display the following screens of operating status data.

BOOKKEEPING 1/2	
COIN 1	0
COIN 2	0
TOTAL COINS	0
COIN CREDITS	0
SERVICE CREDITS	0
TOTAL CREDITS	0
NUMBER OF GAMES	0
SINGLE PLAY	0
MULTI PLAY	0
TOTAL TIME	00D 00H 00M 00S
PLAY TIME	00D 00H 00M 00S
AVERAGE PLAY TIME	00M 00S
LONGEST PLAY TIME	00M 00S
SHORTEST PLAY TIME	00M 00S
BACKUP CLEAR TIME	2008/02/01 XX : XX : XX
PRESS TEST BUTTON TO CONTINUE	

9-3-7 FIG. 01 BOOKKEEPING 1/2

View the number of credits inserted.

- COIN 1: The number of coins inserted in COIN CHUTE 1
- COIN 2: The number of coins inserted in COIN CHUTE 2
- TOTAL COINS: The total number of coins inserted
- COIN CREDITS: The total number of coins inserted
- SERVICE CREDITS: The number of credits added by the SERVICE Button
- TOTAL CREDITS: The total number of credits

View the number of times the game has been played.

- NUMBER OF GAMES: The total number of games played
- SINGLE PLAY: The total number of Single Player Game played
- MULTI PLAY: The total number of Multi Player Game played

View gameplay times.

- TOTAL TIME: The total time
- PLAY TIME: The total play time
- AVERAGE PLAY TIME: The average play time
- LONGEST PLAY TIME: The longest play time
- SHORTEST PLAY TIME: The shortest playtime

You can check the date and time when the BACKUP DATA CLEAR option was executed.

- BACKUP CLEAR TIME: Date and time when backup was cleared last.

Press the TEST Button to move to the screen 2/2 of BOOKKEEPING.

BOOKKEEPING 2/2 TIME HISTOGRAM		
	TOTAL	RATIO
00M00S - 00M59S	0	0%
01M00S - 01M59S	0	0%
02M00S - 02M29S	0	0%
02M30S - 02M59S	0	0%
03M00S - 03M29S	0	0%
03M30S - 03M59S	0	0%
04M00S - 04M29S	0	0%
04M30S - 04M59S	0	0%
05M00S - 05M29S	0	0%
05M30S - 05M59S	0	0%
06M00S - 06M29S	0	0%
06M30S - 06M59S	0	0%
07M00S - 07M29S	0	0%
07M30S - 07M59S	0	0%
08M00S - 08M29S	0	0%
08M30S - 08M59S	0	0%
09M00S - 09M29S	0	0%
09M30S - 09M59S	0	0%
10M00S - 14M59S	0	0%
15M00S - 19M59S	0	0%
20M00S - 24M59S	0	0%
25M00S - 29M59S	0	0%
OVER 30M	0	0%

PRESS TEST BUTTON TO EXIT

9-3-7 FIG. 02 BOOKKEEPING 2/2

Display the number of plays by time length category.

- TIME HISTOGRAM: List of play times

Press the TEST Button to return to the Game Test Menu Screen.

9-3-8 BACKUP DATA CLEAR

Select BACKUP DATA CLEAR to display the following screen.

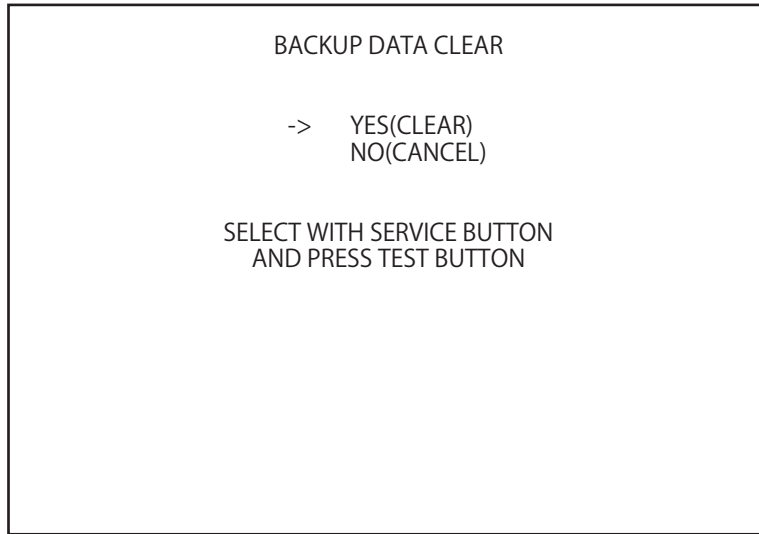

9-3-8 FIG. 01

This screen allows you to clear backup data. Use the cursor to select YES or NO.

- YES: Clear all data in BOOKKEEPING, ranking data and credit data.
- NO: Go back to the menu screen without clearing data.

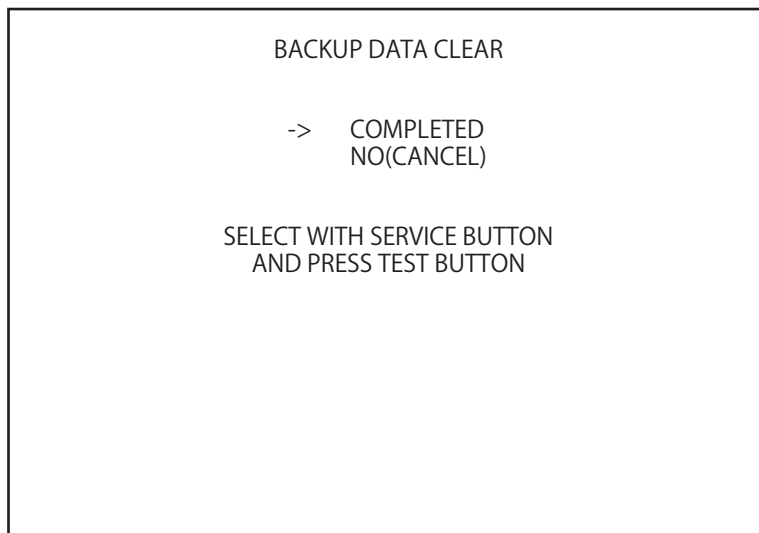

9-3-8 FIG. 02

Select YES and press the TEST Button to clear all data in BOOKKEEPING, ranking data and credit data. Clearing data does not affect other game settings.

When the data has been cleared, the screen displays “COMPLETED”.

Press the TEST Button again to return to the Game Test Menu Screen.

10 CONTROL PANEL

WARNING

- In order to prevent an electric shock and short circuit, be sure to turn power off before performing work by touching the interior parts of the product.
- Be careful not to damage the wires. Damaged wires may cause electric shock or short circuit.
- Do not touch undesignated places. Touching places not designated can cause electric shock or short circuit.
- This work should be performed by the Location's Maintenance Man or Serviceman. Performing work by non-technical personnel can cause electric shock hazard.
- Do not perform work other than those specified in this Manual in order to prevent accidents during performing work and operation after performing work. If performing work other than those stated in this manual is required for repair, contact the offices herein stated in this manual.
- Be very careful when soldering. Handling a soldering iron carelessly may result in a fire or a burn.
- Be extremely careful when heating the heat-shrinkable tube. Failure to do so may result in a fire or burns.
- The motor parts will be very hot after shutting down the game. After shutdown, wait a few moments for the motor parts to cool before you begin working on the unit.
- This unit is a heavy item weighing approximately 20Kg (44.1lbs) Therefore be very careful when performing the work. Use plural workers

CAUTION

- Exercise extreme caution when handling the internal parts of the Control Panel. Watch out for damage, warping and loss. The loss of just one piece may result in damage to or lead to faulty operation of the entire unit.
- Be careful that your fingers do not get caught when opening and closing the control panel, adjusting the VR bracket, or performing other maintenance tasks.
- When securing the plastic-made parts, do not excessively fasten screws and nuts. Failure to observe this may damage the parts and cause injury due to fragments resulting from damage.
- Do not touch the steering wheel when switching on the unit. The steering wheel undergoes automatic initialization after the unit is switched on.

 STOP

IMPORTANT

Be sure to perform volume's move value setting in the INPUT ASSIGNMENTS in the Game Test Mode after replacing or adjusting the Volume.

10-1 OPENING THE CONTROL PANEL

If the steering wheel is not functioning correctly, or if adjusting the volume has no effect in test mode, the volume may not be engaged correctly or it may be defective. Follow the steps below to adjust the gear engagement or replace the volume. In this unit, as long as the volume's maximum range of motion is not exceeded when the steering wheel is turned to the extreme left or right, the volume should not fail. Make sure that the steering wheel is centered (that is to say, positioned to drive directly forward), and install the volume so that its axis is aligned in the direction indicated by the diagram, with the gears engaged appropriately (see 9-2 FIG 01). To adjust or replace the volume, open the control panel according to the steps below. For this task, you will require a tamperproof wrench (for M4 screws).

- 1 Switch off the unit.
- 2 Using a tamperproof wrench, remove the two hexagon socket headed screws from both left and right sides of the Control Panel's front.
- 3 Using a tamperproof wrench, remove the remaining two hexagon socket headed screws from the underside of the Control Panel's front..
- 4 Wiring connections are located behind the Control Panel, be careful not to damage any of the wiring and carefully pull out the Control Panel..
- 5 Unplug the wiring connectors, and the panel may then be totally removed from the cabinet.

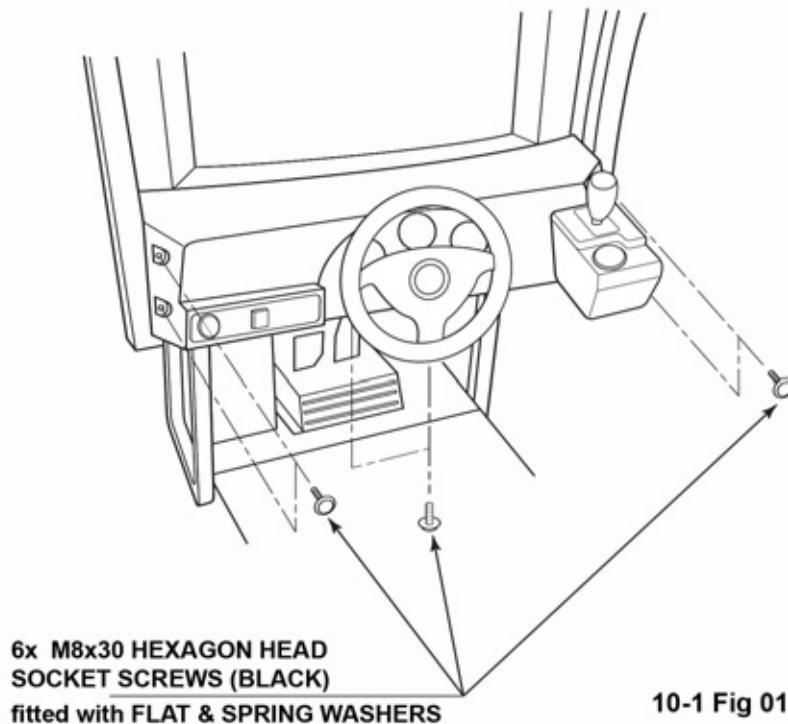

10-2 ADJUSTING/REPLACING THE VOLUME

Adjustment Procedure

- 1 Loosen the two screws that secure the VR bracket, and adjust the gear and the angle of engagement by moving the VR bracket.

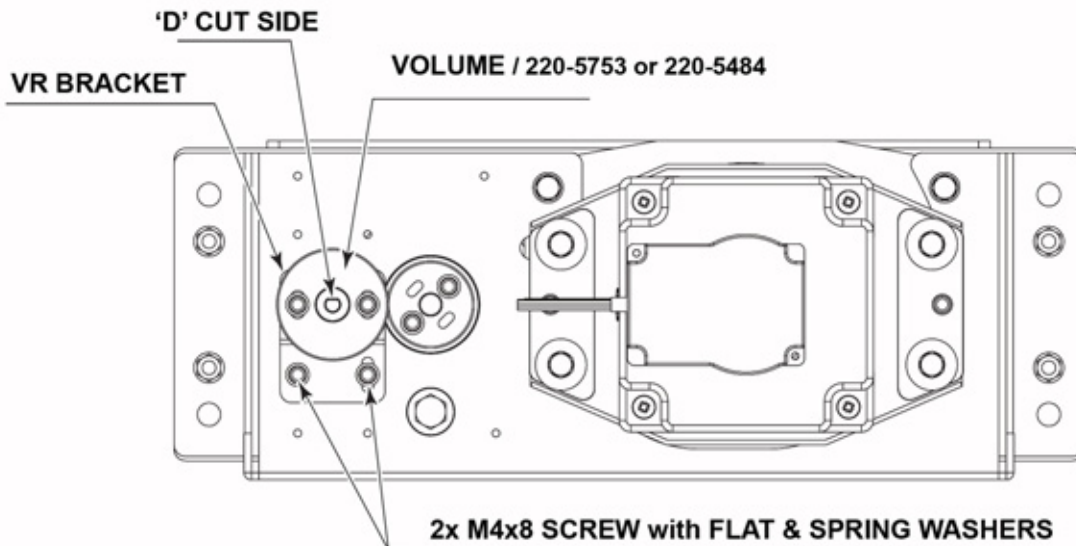

10-2 Fig 01

- 2 Center the steering wheel, and engage the gear while making sure that the D-cut flat edge of the volume axis is aligned in the direction indicated (see 10-2 FIG. 01).
- 3 Tighten the two screws and secure the VR base.
- 4 Turn the steering wheel and check that the gears move smoothly.
- 5 Close and secure the control panel.
- 6 Switch on the unit. Be careful not to touch the steering wheel when doing so. After the unit is switched on, the steering wheel undergoes automatic initialization.
- 7 Configure the volume values on the INPUT ASSIGNMENTS screen in Game Test Mode. It is recommended that the steering wheel volume be set to $80H \pm 8H$ when the steering wheel is centered. Confirm that when the steering wheel is turned to the left the numbers decrease, and when it is turned to the right the numbers increase (see Service Manual).

10-2 ADJUSTING/REPLACING THE VOLUME

Replacement Procedure

When replacing the volume, you will also need to prepare three lengths of heat-shrinkable tubing (Part No.: 310-5029-F20), as well as use the wires that are already soldered onto the volume. For this task, you will need a Phillips-head screwdriver (for M4 screws), a 2 mm hexagon wrench, an 11 to 12 mm adjustable wrench, wire cutter, knife, wire stripper, soldering iron, and work dryer.

- 1 With the Control Panel removed from the machine, remove the Volume Control's connector.
- 2 Remove the two screws that secure the VR bracket and lift out the volume with the bracket.
- 3 Loosen the two Hexagon socket screws on the Gear Holder, and remove the Gear Holder.
- 4 Remove the nuts that secure the VR bracket, and detach the volume from the VR bracket. (See 10-2 FIG. 02)

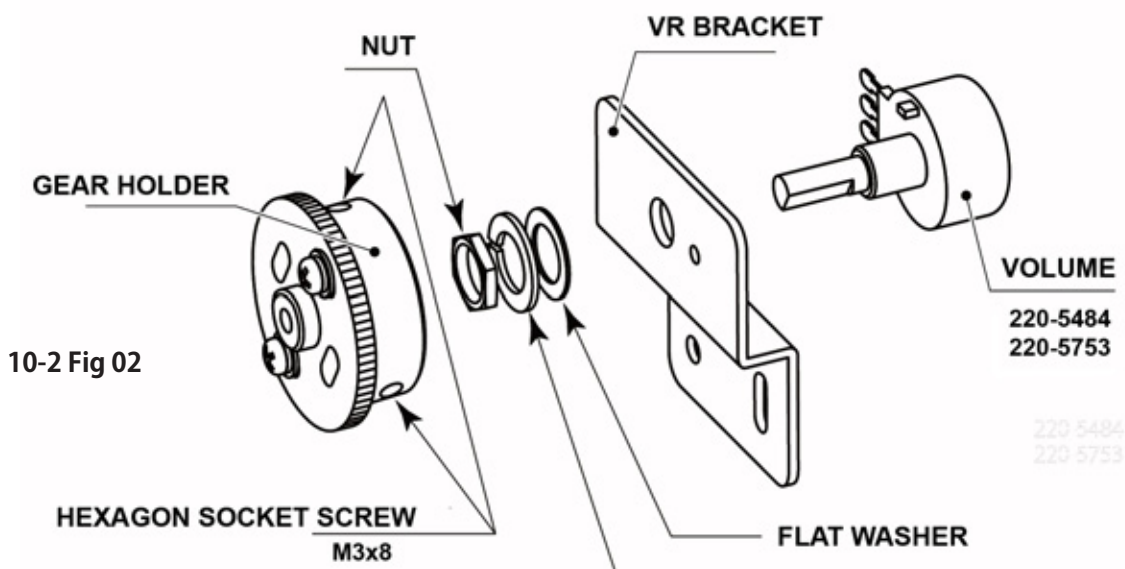

- 5 Using wire cutters or a knife, remove the heat-shrinkable tubing that covers the soldered parts. Melt the solder with a soldering gun, and detach the volume from the wires.
- 6 Cover each wire separately with the heat-shrinkable tubing.
- 7 Solder the wires to each of the new volume's terminals. Carefully check the wiring schematic when connecting the wires to the volume.
- 8 Cover the soldered parts with heat shrinkable tubing, and use the dryer to apply heat until the tubing adheres to the soldered parts.
- 9 Re-attach the VR bracket and gear holder to the volume.
- 10 Refit the VR bracket to the control panel and repeat the sequence on the previous page 'Adjustment Procedure'.

10-3 GREASING

STOP IMPORTANT

- Use only the specified grease. Using any other kind of grease can result in damage to parts.
- Do not apply grease to locations other than as specified. Doing so may create a risk of operational problems and deterioration of parts.
- The period for greasing specified herein is a standard. Apply greasing to the specified portions as occasion arises.

Once every three months, apply grease to the parts indicated.
Use Grease Mate-brand spray grease (Part No.: 090-0066).

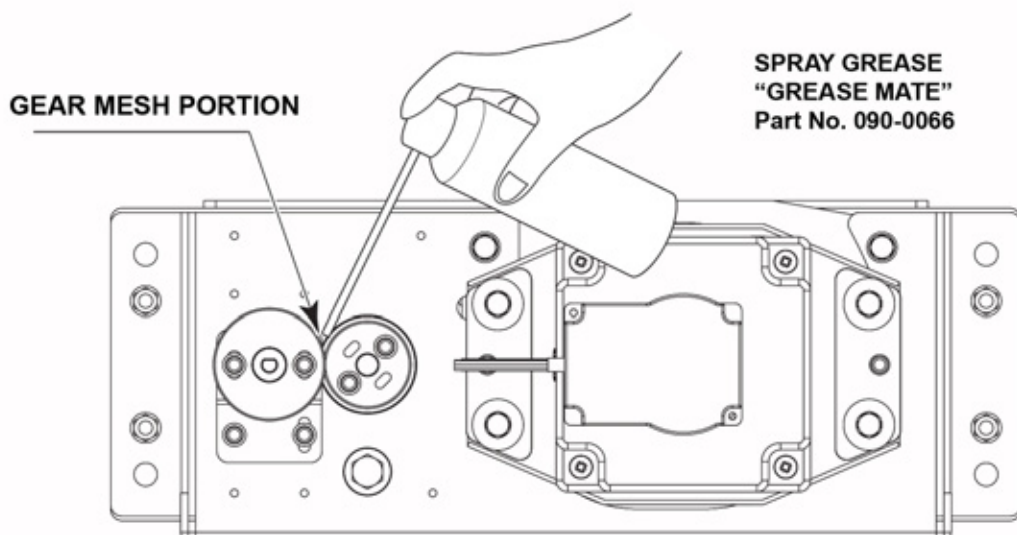

10-3 Fig 01

11 SHIFT LEVER

⚠ WARNING

- When working with the product, be sure to turn the power off. Working with the power on may cause an electric shock or short circuit.
- Be careful not to damage the wires. Damaged wires may cause an electric shock, short circuit or present a risk of fire.

If the shift lever switch input does not function correctly on the INPUT TEST screen, the switch may need to be replaced. To carry out this maintenance, you must first remove the shift lever unit. For this task, you will need a tamperproof wrench (for M5 screws), /and a Phillips-head screwdriver (for M4 screws).

11-1 REMOVING THE SHIFT LEVER

- 1 Turn the power OFF
- 2 Using the M5 tamperproof wrench remove the four tamperproof screws, 1 located in each of the corner of the Shift Lever.
- 3 Gently lift out the Shift Lever to reveal the wiring harness, locate the plug connecting it to the Control panel and remove the connection. The Shift Lever can now be extracted.
- 4 When re-installing the Shift Lever follow the above instructions in the reverse order. At this time ensure that the 'DOWN' display appears on the upper part of the Shift Lever as shown.
- 5 After the Re-installation of the Shift Lever, be sure to check the INPUT TEST in the Game Test mode to determine it's correct operation.

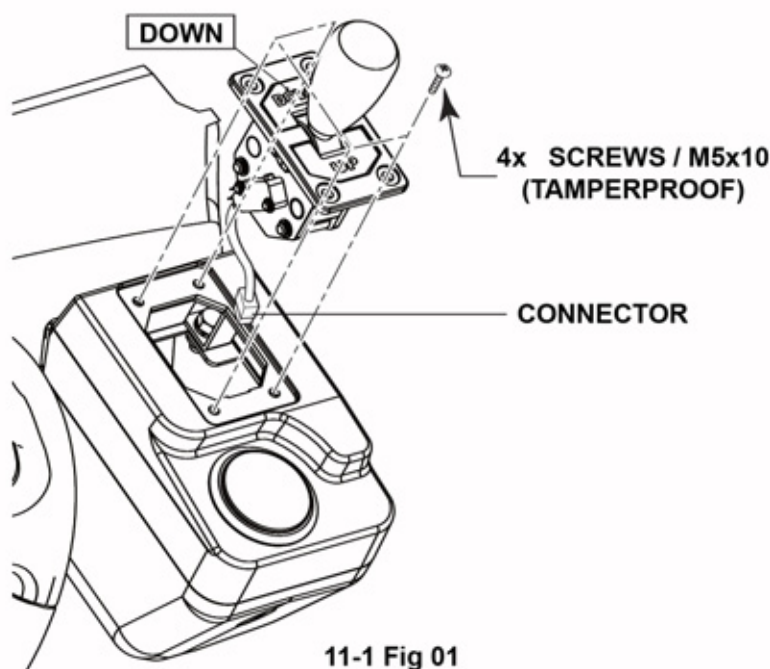

11-1 Fig 01

11-2 SWITCH REPLACEMENT

Follow the instructions below to change the microswitch.

- 1 Unscrew and remove the M3x16 Self Tapping Screws which secure the microswitch to the Gear Shift base.
- 2 Remove the microswitch.
- 3 Remove the wiring harness from the old microswitch and re-attach it to the replacement switch in the same manner.
- 4 Using the M3x10 self tapping screws, refit the replacement microswitch to the Gear Shift base.
- 5 The unit is now ready to be refitted into the control panel, to do this follow in the reverse order 11-1 Removing the Shift Level.

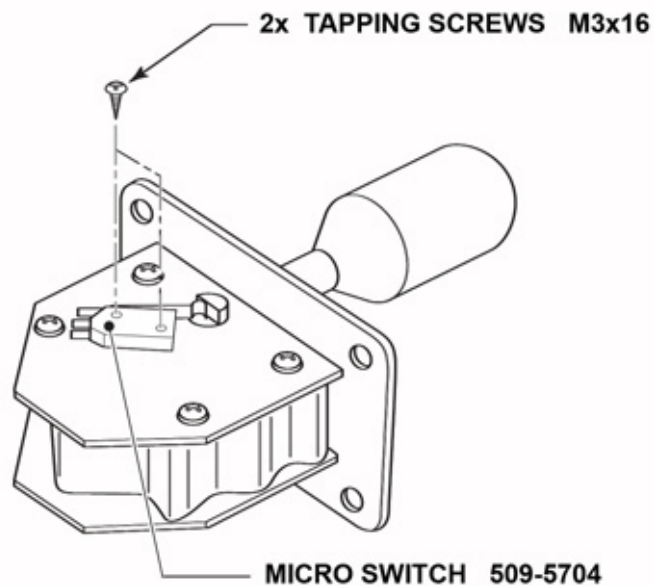

11-2 Fig 01

12 ACCELERATOR & BRAKE

WARNING

- When working with the product, be sure to turn the power off. Working with the power on may cause an electric shock or short circuit. However, the unit must be switched on when using test mode. Do not touch any part of the unit except those areas indicated.
- Be careful not to damage the wires. Damaged wires may cause an electric shock, short circuit or present a risk of fire.
- This work should be performed by site maintenance personnel or other skilled professionals. Work performed by non-technical personnel can cause a severe accident such as an electric shock.
- To prevent accidents while working or while operating the product after it has been installed, be sure not to conduct any procedures other than those given in this manual. There are cases in which procedures not covered in this manual require special tools and skills. If a procedure not given in this manual is required, request service from the office given in this manual or from the point of purchase.

CAUTION

Do not touch the steering wheel when switching the unit on. The steering wheel undergoes automatic initialization immediately after the unit is switched on.

IMPORTANT

Be sure to perform volume's move value setting in the Input Test in the Game Test Mode after replacing or adjusting the Volume.

If the accelerator or brake pedals are not functioning correctly, you may need to adjust the positioning of the volume or replace it with a new one. In addition, you should apply grease to the gear contacts and spring parts once every three months.

12-1 ADJUSTING/REPLACING THE VOLUME

When the accelerator pedal is not being pressed, the accelerator volume should have a value of 30H or less. When the pedal is being pressed, the value should be C0H or greater.

When the brake pedal is not being pressed, the value should be 35H or less. When the pedal is being pressed, it should be D0H or more. You can view these values in test mode. Note that the unit must be switched on to use test mode. Do not touch any part of the unit except those areas indicated when the unit is switch on, as there is a danger of electrical shock or short-circuit.

For this task, you will need a Phillips-head screwdriver (for M4, M5 screws).

Adjusting Procedure

- 1 On the accelerator and brake pedal unit, remove the two truss screws and lift off the front cover.

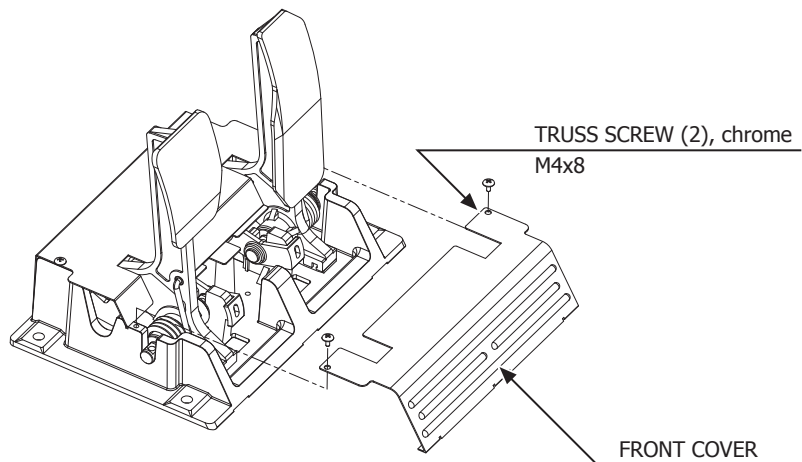

12-1 FIG. 01

- 2 Loosen the single screw that secures the potentiobase, and move the base to adjust the volume values.

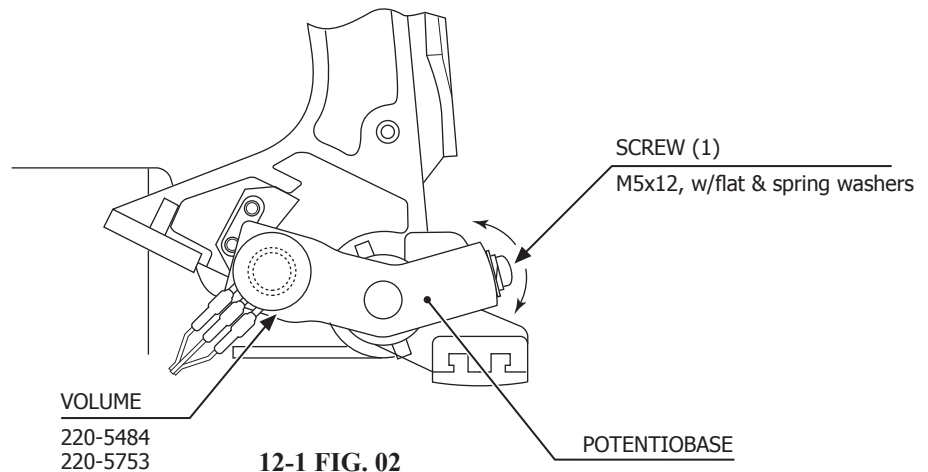

12-1 FIG. 02

- 3 Secure the potentiobase.
- 4 Configure the volume values on the INPUT ASSIGNMENTS screen in Game Test Mode (see Service Manual).
- 5 Check that the values change smoothly in response to pedal input.

Replacing the Volume

- 1 Switch off the unit.
- 2 Remove the two screws and lift off the potentiometer cover.

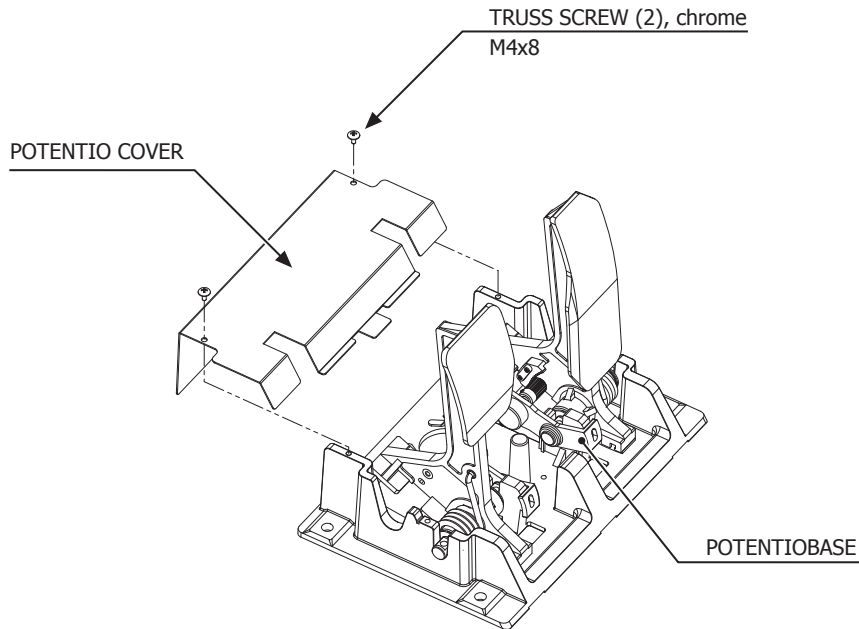

12-1 FIG. 03

- 3 Detach the connector from the volume to be replaced.
- 4 Remove the single screw that secures the potentiometer base (see 12-1 FIG. 02).
- 5 Without detaching the volume, remove the potentiometer base (see 12-1 FIG. 03).
- 6 Remove the base and gear from the volume, and replace it.
- 7 After replacement, configure the volume as described above in “Adjusting Procedure”
- 8 When you have finished, check that the values change smoothly in response to pedal input.

12-2 GREASING

STOP IMPORTANT

Use only the specified grease. Using any other kind of grease can result in damage to parts.

12 ACCELERATOR & BRAKE

Once every three months, you should apply grease to the gear contacts and spring parts. Use Grease Mate-brand spray grease (Part No.: 090-0066).

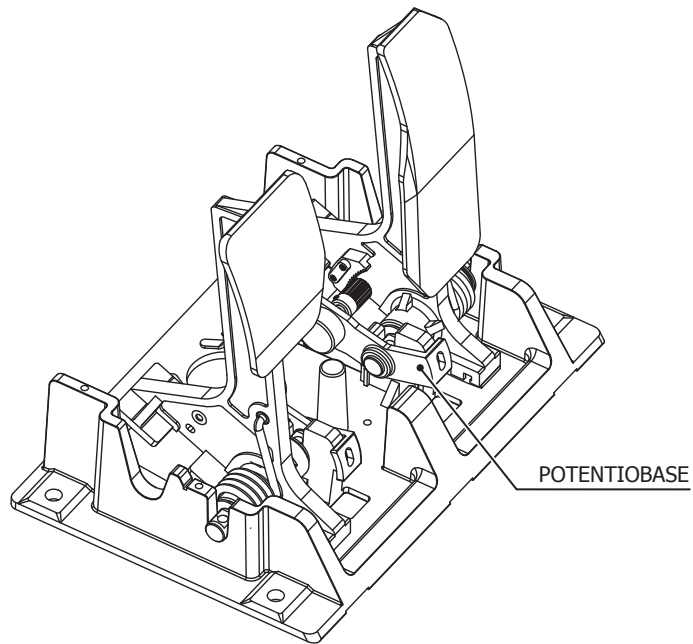

12-2 FIG. 01

13 COIN HANDLING

Handling the Coin Jam

If the coin is not rejected when the REJECT button is pressed, open the coin chute door and open the selector gate. After removing the jammed coin, put a normal coin in and check to see that the selector correctly functions.

Cleaning the Coin Selector

STOP IMPORTANT

- Remove and clean smears by using a soft cloth dipped in water or diluted chemical detergent and then squeezed dry.
- Never apply machine oil, etc. to the Coin Selector.
- After cleaning the Coin Selector, insert a regular coin in the normal working status and ensure that the selector correctly functions.

The Coin Selector should be cleaned once every 3 months.
When cleaning, follow the procedure below:

- 1 Turn the power for the machine OFF. Open the coin chute door.
- 2 Remove the Coin Selector from the coin chute door.
- 3 Open the gate and dust off by using a soft brush (made of wool, etc.).

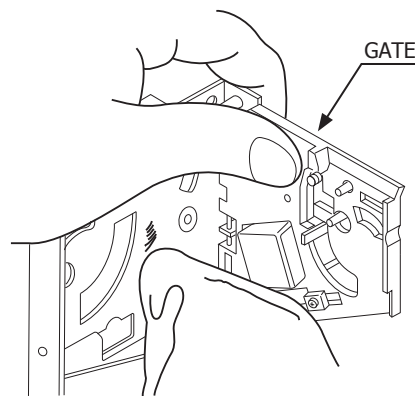

FIG. 13a

- 4 Remove and clean smears by using a soft cloth dipped in water or diluted chemical detergent and then squeezed dry.
- 5 Remove the CRADLE.
When removing the retaining ring (E ring), be very careful so as not to bend the rotary shaft.

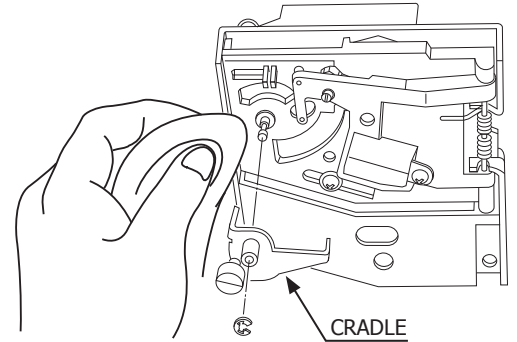

FIG. 13b

- 6 Remove stain from the rotary shaft and shaft receiving portions by wiping off with a soft cloth, etc.
- 7 After wiping off as per previous step, further apply a dry cloth, etc. to cause the Coin Selector to dry completely.

Coin Insertion Test

Once every month, when performing the Coin SW Test, simultaneously check the following:

- Does the Coin Meter count satisfactorily?
- Does the coin drop into the cashbox correctly?
- Is the coin rejected when inserted while keeping the REJECT Button pressed down?

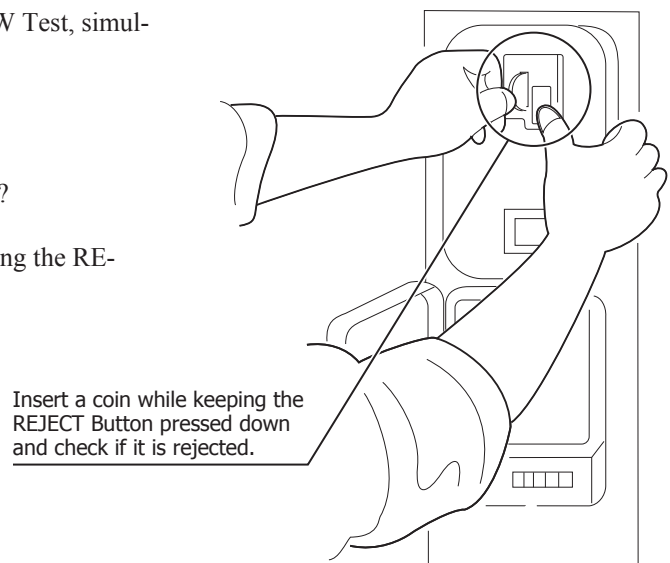

FIG. 13c

Adjusting the Price of Play

This product comes equipped with a Money Controls SR3 Coin Acceptor. To adjust the price of play ALL credit setting are adjusted via the EXCEL CREDIT BOARD.

IMPORTANT!

The CREDIT SETTINGS within the SYSTEM TEST MODE must be set to 1 coin 1 credit to allow the CREDIT BOARD to function correctly.

The VTS board houses 2 DIL Switches. These allow the operator to select the price of play, type of coin acceptor and region.

Excel Credit Board

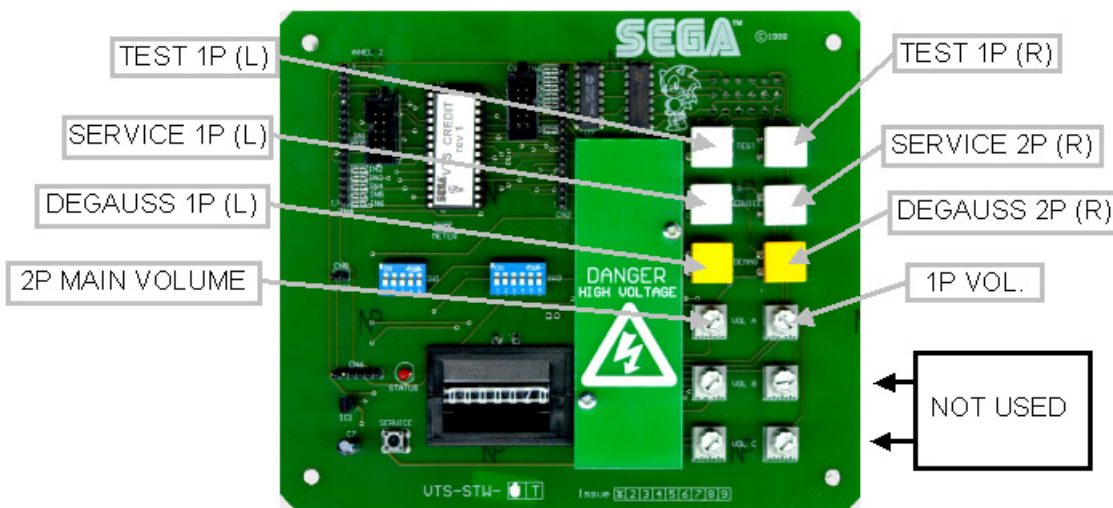

DIL SW3 (Regional Settings)

Adjust these switches to specify the type of Coin Acceptor used and currency. Default = SW1&SW2 ON - SR3 in parallel made, Sterling.

SERVICE BUTON

Provides a service credit when pressed.

Status LED

Flashes when functioning.

O/I Connector

Inputs and Outputs to and from host.

CN5

To secondary SR3 Coin Acceptor.

CH2

To secondary Coin Acceptor (Mars, NRI, ect.)

DIL SW1 (credit settings)

Adjust to required price of pay.

CH1

To primary Coin Acceptor (Mars, Nri, ect.)

CN3

To primary SR3 Coin Acceptor.

REGIONAL AND ACCEPTOR SETTINGS (SW3)

Country	Setting	Switch 3 Setting					Coin Validator Programming										C120-SR3 Only			
		SW1	SW2	SW3	SW4	SW5	SW6	COIN1	COIN2	COIN3	COIN4	COIN5	COIN6	COIN7	COIN8	COIN9	COIN10	COIN11	COIN12	
UK	Coin Controls C220 Parallel	OFF	OFF	OFF	OFF			£1	50p new	20p	10p	-	50p old	-	-	-	-	-	-	
UK	Coin Controls C220 Binary	ON	OFF	OFF	OFF		£1	50p new	20p	-	10p	-	50p old	-	£2	-	-	-	-	
UK	Coin Controls C220 Binary	OFF	ON	OFF	OFF		£1	50p new	20p	-	-	£2	-	50p old	-	-	-	-	-	
UK	Coin Controls SR3 Parallel	ON	ON	OFF	OFF		£1	50p new	20p	-	£2	-	50p old	-	50p old	-	-	-	-	
UK	Coin Controls SR3 Parallel	OFF	OFF	ON	OFF		£2	£1	50p new	20p	10p	-	-	-	-	50p old	-	-	-	
Euro	Coin Controls SR3 Parallel	OFF	OFF	ON	OFF		€2	€1	50p new	20p	10p	-	-	-	-	-	-	-	-	
UK	Mars MEMS 111 Parallel	ON	OFF	ON	OFF		£1	£2	20p	10p	50p new	50p old	-	-	-	-	-	-	-	
UK	NR1 Parallel	OFF	ON	ON	OFF		10p	20p	50p	£1	£2	-	-	-	-	-	-	-	-	
Belgium	Parallel	ON	ON	ON	OFF		-	50Bfr	20Bfr	5Bfr	-	-	-	-	-	-	-	-	-	
Holland	Parallel	OFF	OFF	OFF	ON		-	5NLG	2.5NLG	1NLG	-	-	-	-	-	-	-	-	-	
Austria	SR3 Parallel	ON	OFF	OFF	ON		20Sch	10Sch	5Sch	15Sch	-	-	-	-	-	-	-	-	-	
Spain	Coin Controls C220 Binary	OFF	ON	OFF	ON		500Pta	200Pta	100Pta	50Pta	25Pta	200Pta old	50Pta old	25Pta old	-	-	-	-	-	
Spain	SR3NR1 Parallel	ON	ON	OFF	ON		500Pta	200Pta	100Pta	50Pta	25Pta	-	-	200Pta	-	50Pta old	25Pta old	-	-	
Spain	Coin Controls C220 Parallel	OFF	OFF	ON	ON		100Pta	50Pta new	-	25Pta new	-	50Pta old	-	25Pta old	-	-	-	-	-	
Portugal Euro	Parallel	ON	OFF	ON	ON		200Es	100Es	50Es	-	-	-	-	-	-	-	-	-	-	
	TBA				OFF		TBA													
	Channels						TBA													
							Direct Mode													
							2 channel Mode													

Please Note
The credit board automatically sets the validator for parallel and binary operation through an output on pin 8 of the 17 way pinstrip. For the feature to work it is necessary for the validator interconnecting cable to include a wire at this position

- Note:** These switch settings are under constant review and may change due to world currency updates.
- Set SW 1 according to the option settings found in the relevant Price of Play Settings Table on the following pages.
 - For Germany (DM), France (Fr) & Switzerland (SFr), use the appropriate existing setting shown above (from another country) that matches the coin ratios programmed into your coin mech.
 - Set SW 3 on the VTS /Excel board as shown in the table above corresponding to the country required.

STERLING PRICE OF PLAY SETTINGS (SW1)

Price	Bonus		DILL Switch 1				
			1	2	3	4	5
10p	50p = 5 plays	£1 = 10 plays	OFF	OFF	OFF	OFF	OFF
10p	50p = 6 plays @ 8.33p per play	£1 = 12 plays @ 8.33p per play	ON	OFF	OFF	OFF	OFF
20p	50p = 2.5 plays	£1 = 5 plays	OFF	ON	OFF	OFF	OFF
20p	50p = 3 plays @ 16.66p per play	£1 = 6 plays @ 16.66p per play	ON	ON	OFF	OFF	OFF
30p	50p = 1.66 plays	£1 = 3.33 plays	OFF	OFF	ON	OFF	OFF
30p	50p = 1.66 plays	£1 = 4 plays @ 25p per play	ON	OFF	ON	OFF	OFF
30p	50p = 2 plays @ 25p per play	£1 = 4 plays @ 25p per play	OFF	ON	ON	OFF	OFF
30p	50p = 2 plays @ 25p per play	£1 = 3 plays @ 33.33p per play	ON	ON	ON	OFF	OFF
40p	50p = 1.25 plays	£1 = 2.5 plays	OFF	OFF	OFF	ON	OFF
40p	50p = 1.25 plays	£1 = 3 plays @ 33.3p per play	ON	OFF	OFF	ON	OFF
50p	50p = 1 play	£1 = 2 plays	OFF	ON	OFF	ON	OFF
50p	50p = 1 play	£1 = 3 plays @ 33.3p per play	ON	ON	OFF	ON	OFF
50p	50p = 1 play	£1 = 2 plays	OFF	OFF	ON	ON	OFF
60p	50p = 0.83 play	£1 = 1.66 plays	ON	OFF	ON	ON	OFF
60p	50p = 0.83 play	£1 = 2 plays @ 50p per play	OFF	ON	ON	ON	OFF
80p	50p = 0.62 play	£1 = 1.25 plays	ON	ON	ON	ON	OFF
80p	£1 = 1.25 plays	£1.50 = 2 plays @ 75p per play	OFF	OFF	OFF	OFF	ON
£1	2x50p = 1 play	£1 = 1 play	ON	OFF	OFF	OFF	ON
£1	2x50p = 1 play	£1 = 1 play	OFF	ON	OFF	OFF	ON
£1	2x50p = 1 play	£2 = 2 plays	ON	ON	OFF	OFF	ON
£1.50	3x50p = 1 play	£1 = 0.66 plays	OFF	£4 = 5 plays @ 80p per play	OFF	OFF	ON
£1.50	3x 50p = 1 play	£1 = 0.66 plays	ON	£3 = 2 plays	OFF	OFF	ON
£2	4x 50p = 1 play	£1 = 0.5 play	OFF	£2 = 2 plays @ £1 per play	ON	OFF	ON
£2	4x 50p = 1 play	£1 = 0.5 play	ON	£2 = 1 play	ON	OFF	ON
£3	6x50p = 1 play	£1.50 = 0.5 play	OFF	£5 = 3 plays @ £1.66 per play	ON	ON	ON
£3	6x50p = 1 play	£1.50 = 0.5 play	OFF	£3 = 1 play	OFF	OFF	ON
£5	£1 = 0.2 play	£1.50 = 0.5 play	ON	£5 = 2 plays @ £2.50 per play	ON	OFF	ON
£5	£1 = 0.2 play	£5 = 1 play	OFF	£10 = 2 plays	OFF	ON	ON
£7.50	£5 = 0.66 play	£10 = 1.33 plays	ON	£10 = 3 plays @ £3.33p per play	ON	ON	ON
£7.50	£5 = 0.66 play	£10 = 1.33 plays	OFF	£15 = 2 plays	OFF	ON	ON
£10	£10 = 1 play	£20 = 2 play	ON	£10 = 2 plays @ £5 per play	ON	OFF	ON
		Free Play	OFF	£30 = 3 play	OFF	ON	ON
			ON		ON	ON	ON

EURO PRICE OF PLAY SETTINGS (SW1)

Price	Bonus					DIL Switch 1				
	1	2	3	4	5	1	2	3	4	5
10¢	50¢ = 5 plays	€1 = 10 plays	€2 = 20 plays			OFF	OFF	OFF	OFF	OFF
10¢	50¢ = 6 plays @ 8.33p per play	€1 = 12 plays @ 8.33¢ per play	€2 = 24 plays @ 8.33¢ per play			ON	OFF	OFF	OFF	OFF
20¢	50¢ = 2.5 plays	€1 = 5 plays	€2 = 10 plays			OFF	ON	OFF	OFF	OFF
20¢	50¢ = 3 plays @ 16.66¢ per play	€1 = 6 plays @ 16.66¢ per play	€2 = 12 plays @ 16.66¢ per play			ON	ON	OFF	OFF	OFF
30¢	50¢ = 1.66 plays	€1 = 3.33 plays	€2 = 6.66 plays			OFF	OFF	ON	OFF	OFF
30¢	50¢ = 1.66 plays	€1 = 4 plays @ 25¢ per play	€2 = 8 plays @ 25¢ per play			ON	OFF	ON	OFF	OFF
30¢	50¢ = 2 plays @ 25¢ per play	€1 = 4 plays @ 25¢ per play	€2 = 8 plays @ 25¢ per play			OFF	ON	ON	OFF	OFF
30¢	50¢ = 2 plays @ 25¢ per play	€1 = 3 plays @ 33.33¢ per play	€2 = 6 plays @ 33.33¢ per play			ON	ON	ON	OFF	OFF
40¢	50¢ = 1.25 plays	€1 = 2.5 plays	€2 = 5 plays			OFF	OFF	OFF	ON	OFF
40¢	50¢ = 1.25 plays	€1 = 3 plays @ 33.33¢ per play	€2 = 6 plays @ 33.33¢ per play			ON	OFF	OFF	ON	OFF
50¢	50¢ = 1 play	€1 = 2 plays	€2 = 4 plays			OFF	ON	OFF	ON	OFF
50¢	50¢ = 1 play	€1 = 3 plays @ 33.33¢ per play	€2 = 6 plays @ 33.33¢ per play			ON	ON	OFF	ON	OFF
50¢	50¢ = 1 play	€1 = 2 plays	€2 = 5 plays @ 40¢ per play			OFF	OFF	ON	ON	OFF
60¢	50¢ = 0.83 play	€1 = 1.66 plays	€2 = 3.33 plays			ON	OFF	ON	ON	OFF
60¢	50¢ = 0.83 play	€1 = 2 plays @ 50¢ per play	€2 = 4 plays @ 50¢ per play			OFF	ON	ON	ON	OFF
80¢	50¢ = 0.62 play	€1 = 1.25 plays	€2 = 2.5 plays			ON	ON	ON	ON	OFF
80¢	€1 = 1.25 plays	€1.50 = 2 plays @ 75¢ per play	€2 = 2.5 plays			OFF	OFF	OFF	OFF	ON
€1	2x50¢ = 1 play	€1 = 1 play	€2 = 2 plays			ON	OFF	OFF	OFF	ON
€1	2x50¢ = 1 play	€1 = 1 play	€2 = 3 plays @ 66.6¢ per play			OFF	ON	OFF	OFF	ON
€1	2x50¢ = 1 play	€2 = 2 plays	€4 = 5 plays @ 80¢ per play			ON	ON	OFF	OFF	ON
€1.50	3x50¢ = 1 play	€1 = 0.66 plays	€3 = 2 plays			OFF	OFF	ON	OFF	ON
€1.50	3x 50¢ = 1 play	€1 = 0.66 plays	€2 = 2 plays @ €1 per play			ON	OFF	ON	OFF	ON
€2	4x 50¢ = 1 play	€1 = 0.5 play	€2 = 1 play			OFF	ON	ON	OFF	ON
€2	4x 50¢ = 1 play	€1 = 0.5 play	€5 = 3 plays @ €1.66 per play			ON	ON	ON	OFF	ON
€3	6x50¢ = 1 play	€1.50 = 0.5 play	€3 = 1 play			OFF	OFF	OFF	ON	ON
€3	6x50¢ = 1 play	€1.50 = 0.5 play	€5 = 2 plays @ €2.50 per play			ON	OFF	OFF	ON	ON
€5	€1 = 0.2 play	€5 = 1 play	€10 = 2 plays			OFF	ON	OFF	ON	ON
€5	€1 = 0.2 play	€5 = 1 play	€10 = 3 plays @ 3.33¢ per play			ON	ON	OFF	ON	ON
€7.50	€5 = 0.66 play	€10 = 1.33 plays	€15 = 2 plays			OFF	OFF	ON	ON	ON
€7.50	€5 = 0.66 play	€10 = 1.33 plays	€10 = 2 plays @ €5 per play			ON	OFF	ON	ON	ON
€10	€10 = 1 play	€20 = 2 play	€30 = 3 play			OFF	ON	ON	ON	ON
32	Free Play					ON	ON	ON	ON	ON

SELECTING STERLING / EURO OPTION

The SR3 coin acceptor (supplied) is programmed to accept UK Sterling and the Euro. Factory setting is for the UK Sterling. If the configuration needs to change to the Euro, then please follow the instructions below for changing over to the Euro and visa versa.

BANK SELECT

This function allows you to enable both or individual select banks of coins via switches 7 and 8 on the 8 way DIL switch.

This enables the selection of 2 different currencies, one in each bank, or 12 coins/tokens in both banks from the same country.

To enable/disable the banks set the switches as show below.

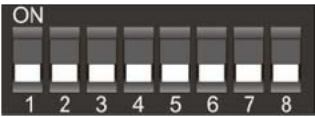

Both Banks ON (enabled) - **Sterling and Euro's**

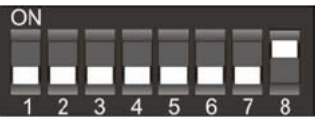

Bank 1 ON (enabled) and Bank 2 OFF (disabled) - **Sterling ONLY**

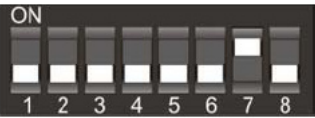

Bank 1 OFF (disabled) and Bank 2 ON (enabled) - **Euro's ONLY**

Please remove power from the SR3 before changing the status on the DIP SW.

TEACH AND RUN PROGRAMMING (SR3)

If the machine is positioned in location where only tokens are used, then the SR3 Coin Acceptor can be programmed to accept and credit special coins/tokens.

Please follow the instructions below to enable and program the TEACH & RUN facility.

Table 1: Teach & Run Programming Bank 1.

Coin Number	SW1	SW2	SW3	SW4	SW5	SW6
1	off	off	off	ON	ON	off
2	off	off	ON	off	ON	off
3	off	off	ON	ON	ON	off
4	off	ON	off	off	ON	off
5	off	ON	off	ON	ON	off
6	off	ON	ON	off	ON	off

Bank 2

Table 2: Teach & Run Programming Bank 2

Coin Number	SW1	SW2	SW3	SW4	SW5	SW6
7	off	ON	ON	ON	ON	off
8	ON	off	off	off	ON	off
9	ON	off	off	ON	ON	off
10	ON	off	ON	off	ON	off
11	ON	off	ON	ON	ON	off
12	ON	ON	off	off	ON	off

Teach and Run EXAMPLE. (To teach coin channel 12 for £1)

Switch off the power to the SR3 and set the Program DIL switches to:-



MSB SW1	SW2	SW3	LSB SW4	TOTAL	SW5	SW6
ON	ON	OFF	OFF	12	ON	OFF

Switch on the power to the SR3.

Press the reject lever within 20 seconds. The LED will turn RED.

Start entering £1 coins until the LED flashes GREEN, typically after 8 to 10 insertions.

NOTE: If the LED turns GREEN after the 1st coin, then the Teach & Run is DISABLED.

Press the reject lever and the LED will turn GREEN. The coin channel has now been programmed.
SET ALL SWITCHES TO THE OFF POSITION.

14 MONITOR

14-1 CAUTIONS AND WARNINGS CONCERNING THE SAFETY FOR HANDLING THE MONITORS

Before handling the monitors, be sure to read the following explanations and comply with the caution/warning instructions given below. Note that the caution/warning symbol marks and letters are used in the instructions.

⚠ WARNING Indicates that handling the monitors erroneously by disregarding this warning may cause a potentially hazardous situation, which could result in death or serious injury.

⚠ CAUTION Indicates that handling the monitors by disregarding this caution may cause a potentially hazardous situation, which could result in personal injury and or material damage.

Indicates that access to a specific part of the equipment is forbidden.

Indicates the instruction to disconnect a power connector or to unplug.

⚠ WARNING

- When performing such work as installing and removing the monitor, inserting and disconnecting the external connectors to and from monitor interior and the monitor, be sure to disconnect the power connector (plug) before starting the work. Proceeding the work without following this instruction can cause electric shock or malfunctioning.
- Using the monitor by converting it without obtaining a prior permission is not allowed. SEGA shall not be liable for any malfunctioning and accident caused by said conversion.

⚠ WARNING

- Primary side and Secondary side

The monitor's circuit which is divided into the Primary side and Secondary side, is electrically isolated. Do not touch the primary side, or do not touch both the primary side and the secondary side simultaneously. Failing to observe the instruction can cause electric shock and this is very dangerous. When making monitor adjustments, use a nonconductive driver and make adjustment without touching any part other than the Adjustment V. R. and knob. Also, be sure not to cause a short-circuit to the Primary side and Secondary side. If short-circuited, it can cause electric shock or malfunctioning, which is very dangerous.

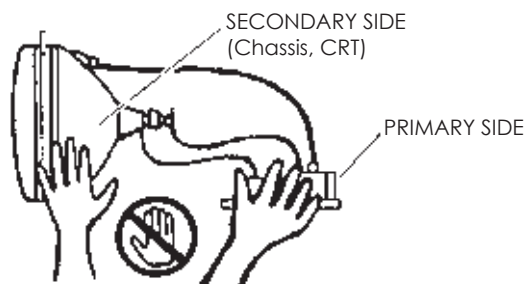

14-1 FIG. 01

WARNING

- **High-tension Voltage**
Some of the parts inside monitor are subject to high-tension voltage in excess of 20,000 volts and very dangerous. Therefore, do not touch the monitor interior. Should soldering & paper wastes, etc. be mixed in the monitor interior, turn the power off so as not to cause malfunctioning or fire hazard.

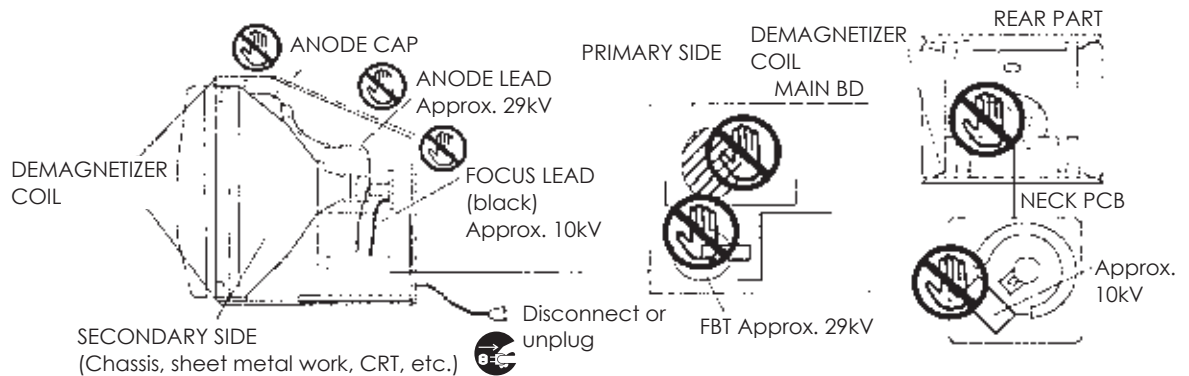

14-1 FIG. 02

- **Connecting the CRT and PCB**
For combining the CRT and PCB, use the specified part No. to maintain the status of adjustments made at the factory. The anode of the CRT itself will be accumulatively charged as time elapses, generating high-tension voltage which is very dangerous. The monitor should be used with the Chassis, CRT and PCB assembled. When repair, etc. is required at the time of malfunctioning, be sure to send it in an "as is assembled" condition. If these are disassembled, what's charged to said high tension voltage can be discharged, causing a very hazardous situation. Therefore, under no circumstances should it be disassembled.

CAUTION

- **Static Electricity**
Touching the CRT surface sometimes causes you to slightly feel electricity. This is because the CRT surfaces are subject to static and will not adversely affect the human body.
- **Installation and removal**
Ensure that the Demagnetizer Coil, FBT (Fly-Back Transformer), Anode Lead and Focus Lead are not positioned close to the sheet metal work's sharp edges, etc. and avoid damaging the insulated portions so as not to cause electric shock and malfunctioning. (For the name of parts, refer to the above Figures).

CAUTION

For the purpose of static prevention, special coating is applied to the CRT face of this product. To protect the coating, pay attention to the following points. Damaging the coating film can cause electric shock to the customers.

- Do not apply or rub with a hard item (a rod with pointed edge, pen, etc.) to or on the CRT surfaces.
- Avoid applying stickers, seals, etc. on the CRT face.
- Do not remove aluminum foils from the CRT corners. Removing the aluminum foils can cause static prevention effects to be lowered.

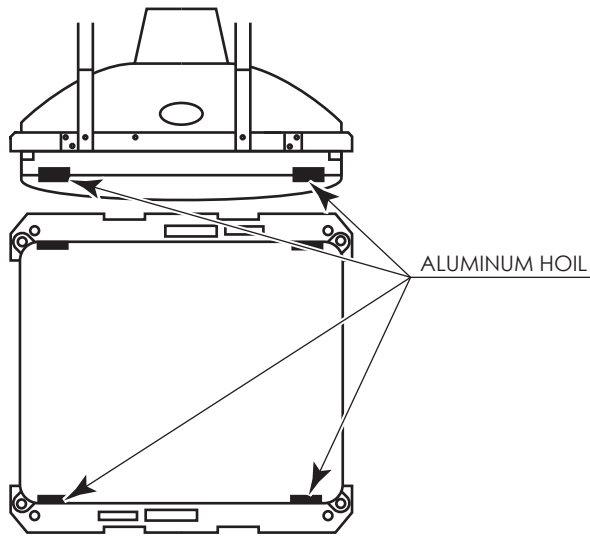

14-1 FIG. 03

14-2 CLEANING THE CRT SURFACES

CAUTION

Static preventive coating is applied to the CRT surfaces. When cleaning, pay attention to the following points. Peeling off of static preventive coat can cause electric shock.

- Remove smears by using a dry, soft cloth (flannels, etc.). Do not use a coarse gauze, etc.
- For smear removing solvent, alcohol (ethanol) is recommended. When using chemical detergent, be sure to follow instructions below:
 - Dilute chemical detergent with water and dip a soft cloth in and then thoroughly wring it to wipe smears off.
 - Do not use a chemical detergent containing an abradant, powder or bleaching agent.
 - Do not use alkaline chemical detergents such as "glass cleaner" available on the market or solvents such as thinner, etc.
- Do not rub or scratch the CRT face with hard items such as brushes, scrub brush, etc.

Clean the CRT surfaces once a week. When cleaning, pay attention to the above caution so that the antistatic coating will not come off.

14-3 ADJUSTMENT PROCEDURE

!WARNING

- Monitor adjustments have been made at the time of shipment. Therefore, do not make further adjustment without a justifiable reason. Adjusting the monitor which contains high tension parts is dangerous work. Also, an erroneous adjustment can cause deviated synchronization and image fault, resulting in malfunctioning.
- Be sure to perform appropriate adjustment of the monitor (projector). For operation of this machine, do not leave monitor's flickering or deviation as is. Failure to observe this can cause to worsen the players' or the customers' physical conditions.
- Do not touch undesignated places. Touching places not designated can cause electric shock or short circuit.

To make monitor adjustment, take off the 2 truss screws from CRT Adjustment Panel portion. The Adjustment BD appears when the screws are removed.

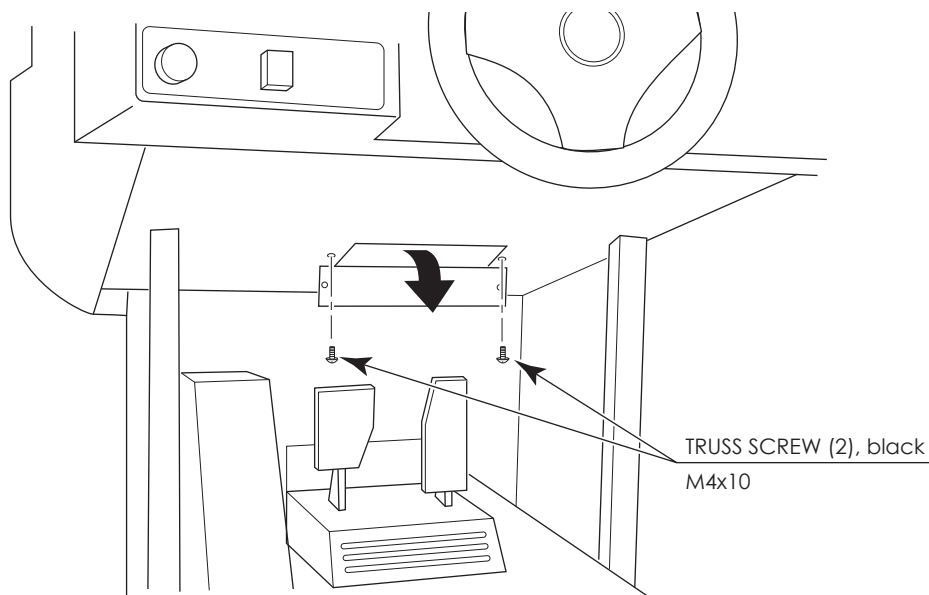

14-3 FIG. 01

This product's monitor is 200-6095. For adjustment method, carefully read and carry out the following. With this product, the hue of each color cannot be adjusted.

- A: FUNC (SA04)
- B: UP (SA03)
- C: DOWN (SA01)
- D: DEGAUSS (SA05)

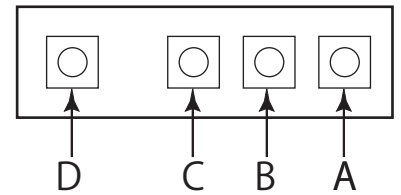

14-3 FIG. 02

There are four buttons to operate the adjustment.

Pressing FUNC button displays the following menu screen. The item chosen is red, and the others are green.

When there is no input of the button for 6 seconds, the menu display disappears.

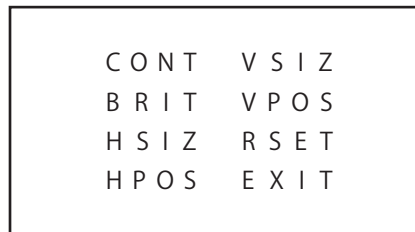

14-3 FIG. 03

- CONT : adjusts image contrast.
With the UP button, it becomes deep and becomes light with the DOWN button.
- BRIT : adjusts the on-screen image brightness.
With the UP button, it becomes bright and becomes dark with the DOWN button.
- HSIZ : adjusts the horizontal image size.
With the UP button, it becomes large and becomes small with the DOWN button.
- HPOS : adjusts the horizontal image's position.
With the UP button, it moves to the left and moves to the right with the DOWN button.
- VSIZ : adjusts the vertical image size.
With the UP button, it becomes large and becomes small with the DOWN button.
- VPOS : adjusts the vertical image's position.
With the UP button, it moves upwards and moves downwards with the DOWN button.
- EXIT : ends the adjusting mode and exits the menu.

- Each time the FUNC button is pressed, the selection item (red display) moves in following order.

CONT → BRIT → HSIZ → HPOS → VSIZ → VPOS → RSET → EXIT → CONT →

- Select the item (red display) and press the UP or the DOWN button once, the following display will appear.

Contrast Adjusting Screen

The "nnn" is a present value of the adjustment value.



14-3 FIG. 04

Pressing the UP/DOWN button again causes the adjusting works to be done.

When there is no input of the UP/DOWN button for 6 seconds or the FUNC button is pressed, the adjustment value is memorized.

- If EXIT is selected (red display) and the UP/DOWN button is pressed, the adjustment mode will be canceled and the menu display will disappear.
- Selecting RSET and pressing the UP and the DOWN buttons simultaneously causes "RSET" to be displayed for 3 seconds and this resets the on-screen setting status to the factory setting.
- When pressing the DEGAUSS button, degaussing is performed for 5 seconds and displays "DEGAUSS". Once degaussed, it takes 5 minutes or longer to have degaussing function again. If it is pressed before taking 5 minutes, the following screen will appear for the remaining seconds.



14-3 FIG. 05

15 FLUORESCENT LIGHT/OTHER LAMPS REPLACEMENT

WARNING

- When working with the product, be sure to turn the power off. Working with the power on may cause an electric shock or short circuit.
- You may get burned by a hot fluorescent lamp or other lamps. Pay full attention to the lamps when performing the work.
- Be sure to use lamps of the designated rating. Using lamps of undesignated rating can cause a fire or malfunctioning.
- There is the danger of short circuits or smoke generation due to deterioration of insulation in lighting fixtures resulting from age deterioration. Check for anomalies such as the following: Does it smell like something is burning? Is there socket discoloration? Are any lamps being replaced frequently? Do lamps not go on properly?

CAUTION

- Be careful when handling the plastic parts. Failure to observe this may cause injury or damage due to fragments, etc.
- Do not attempt to replace billboard fluorescent lamps while standing on the base. If you should misstep while working, you could stumble or fall down.

Remove the rear cover from the ASSY BILLBOARD by unscrewing the 3x Philips fixings.

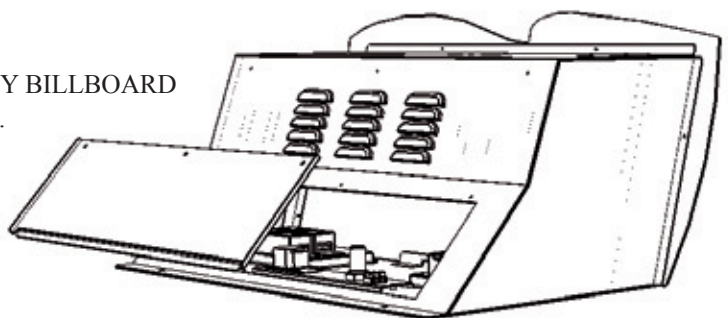

15 FIG. 01

- 3 The Fluorescent Lamp is positioned on the rear wall of the BILLBOARD BOX. To remove carefully push the lamp towards the rear of the cabinet (Seat side). This will then allow the lamp to be accessed through the REAR access panel.

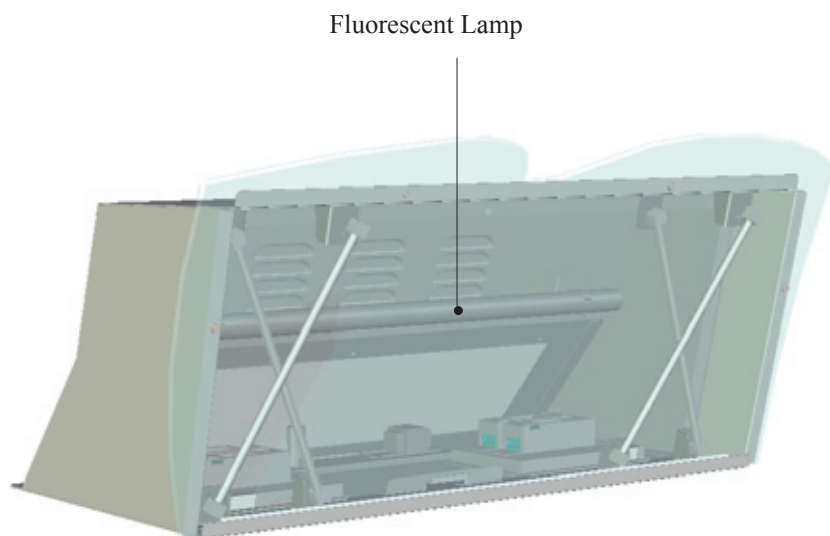

15 FIG. 03

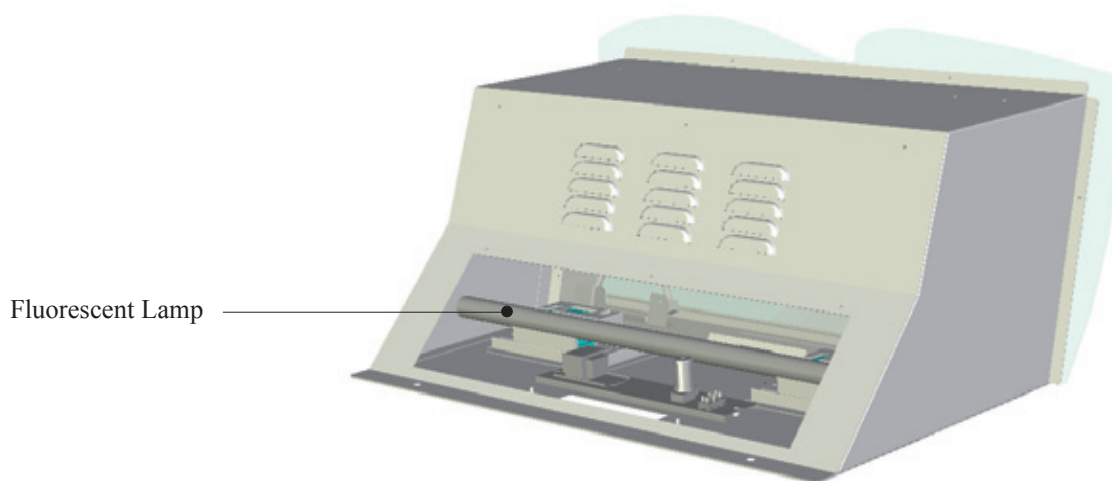

15 FIG. 04

Start Button Lamp, View Change Button Lamp

- 1 Turn off the power.
- 2 Remove the 4 tamperproof screws.

TAMPERPROOF SCREW (4), chrome
M4x16

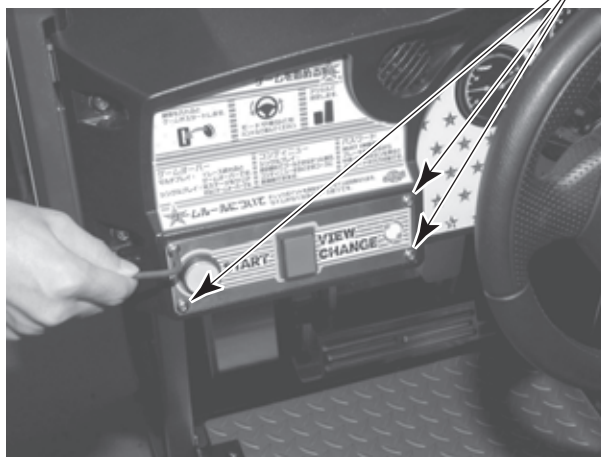

15 FIG. 05

- 3** Remove the Switch Plate. The Switch Plate contains wiring connections. Disconnect the connector, taking care not to damage the wiring.

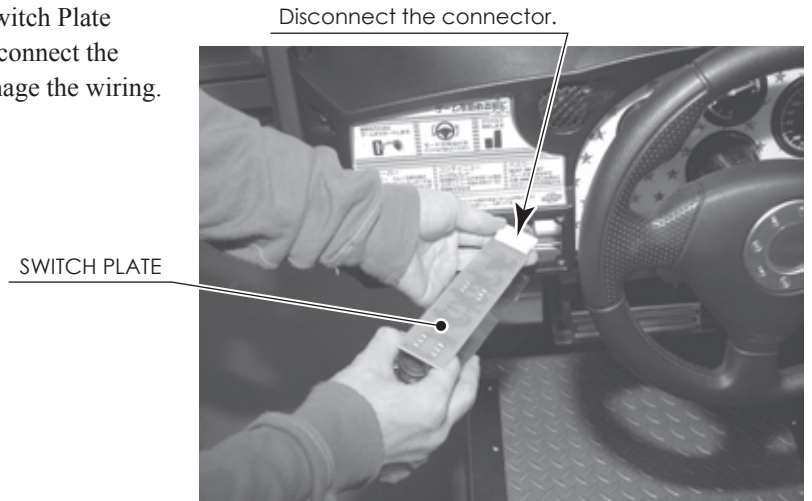

15 FIG. 06

- 4** There is a metal fitting at the base of the buttons on the Button Plate. Rotate this metal fitting to unlock it, then remove the printed circuit board from the Button Plate.

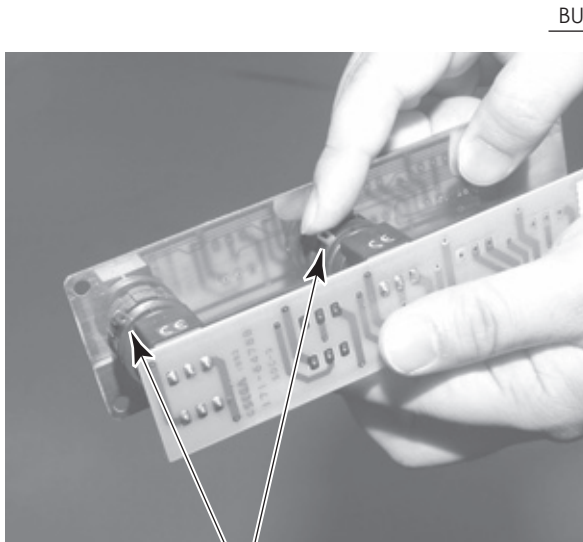

15 FIG. 07

Unlock.

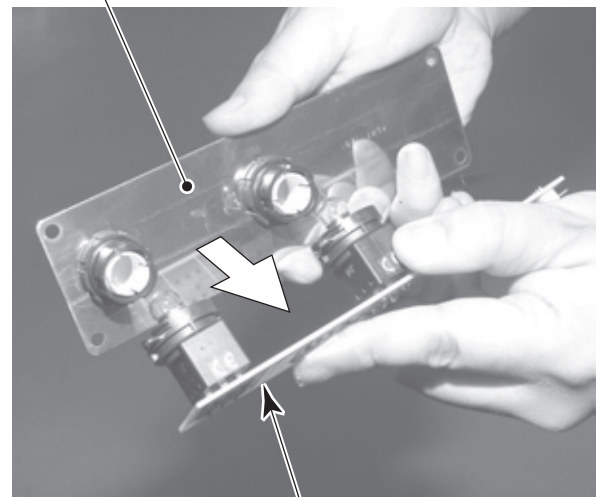

15 FIG. 08

- 5** Press and turn the lamp counter-clockwise to remove it.

LAMP 6.3V 1W
390-5445-01

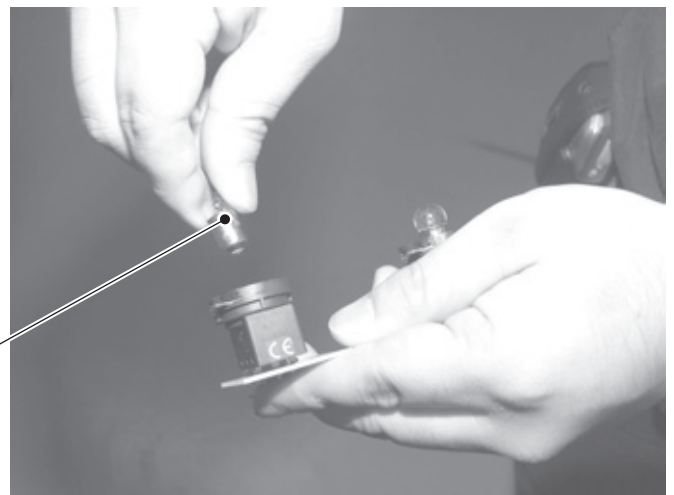

15 FIG. 09

16 PERIODIC INSPECTION

The items listed below require periodic check and maintenance to retain the performance of this machine and to ensure safe business operation.

When handling the controller, the player will be in direct contact with it. In order to always allow the player to enjoy the game, be sure to clean it regularly. Also, it is advisable to provide wet tissue, etc. available for player use.

WARNING

- **Once a year, check to see if power cords are damaged, the plug is securely inserted, dust is accumulated between the socket outlet and the power plug, etc. Using the product with accumulated dust in the interior may cause fire or electric shock.**
- **Never use a water jet, etc. to clean the inside and outside of the cabinet. If wetness occurs for any reason, do not use the product until it has completely dried.**
- **Once a year, request the office shown on this manual or the dealer from whom the product was originally purchased to perform the internal cleaning. Using the product with accumulated dust in the interior may cause fire or other accidents. Note that you are liable for the cost of cleaning the interior parts.**
- **There is the danger of accidents involving electrical shorts circuits or fire caused by factors such as the deterioration of insulation in electrical and electronic equipment over time. Check that there are no abnormalities such as odors from burning.**

16 TABLE 01 PERIODIC INSPECTION TABLE

ITEMS	DESCRIPTION	PERIOD	REFERENCE
CABINET	Confirm that adjusters contact floor	Daily	3
CONTROL PANEL	Volume inspection	Monthly	9, 10
	Gear alignment inspection	Every 3 months	10-2
	Greasing	Every 3 months	10-3
SHIFT LEVER	Switch inspection	Monthly	9, 11
	Greasing	Every 3 months	11-3
ACCELERATOR & BRAKE	Volume inspection	Monthly	9, 12
	Gear and spring portion greasing	Every 3 months	12-2
MONITOR	Screen cleaning	Weekly	14-2
	Confirm settings	Monthly or when moving	6, 9, 14
COIN CHUTE DOOR	Coin switch inspection	Monthly	9
	Coin insertion test	Monthly	13
	Selector cleaning	Every 3 months	13
SEAT	Greasing to the seat rail	Every 3 months	16 FIG. 01
GAME BD	Memory Test	Monthly	9
	Confirm settings	Monthly	9
POWER CABLES	Inspection, Cleaning	1 year	As above
INTERIOR	Cleaning	1 year	As above
CABINET SURFACES	Cleaning	As appropriate	Next page

Cleaning the Cabinet Surfaces

When the cabinet surfaces are badly soiled, remove stains with a soft cloth dipped in water or diluted (with water) chemical detergent and squeezed dry. To avoid damaging surface finish, do not use such solvents as thinner, benzine, etc. other than ethyl alcohol, or abrasives, bleaching agent and chemical dustcloth.

Some general-purpose household, kitchen and furniture cleaning products may contain strong solvents that degrade plastic components, coatings, and print. Before using any cleaning product, read the product's cautionary notes carefully and test the product first on a small area that is not highly visible.

Seat (Greasing to Seat Rail Portion)

Move the Seat to the rearmost position and apply spray greasing to the portion shown at the right once every 3 months by using NOK KLUBER L60 or GREASE MATE SEGA PART No. 090-0066.

After greasing, move the Seat a few times forward and backward so as to allow the grease to be applied all over uniformly.

Be sure to wipe grease which attaches to the surfaces of the PROTECT RUBBER on the Seat Rail, or any excess grease.

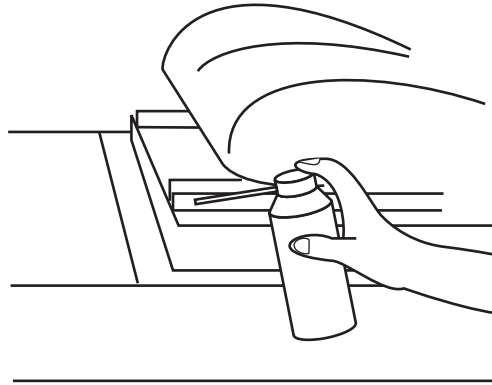

16 FIG. 01

17 TROUBLESHOOTING

17-1 TROUBLESHOOTING (WHEN NO ERROR MESSAGE IS SHOWN)

WARNING

- In order to prevent electric shock and short circuit, be sure to turn power off before performing work.
- Be careful so as not to damage wirings. Damaged wiring can cause electric shock or short circuit.
- After removing the cause of the functioning of the Circuit Protector, reinstate the Circuit Protector. Depending on the cause of the functioning, using the Circuit Protector as is without removing the cause can cause generation of heat and fire hazard.
- In the event that a problem cannot be resolved by employing the procedures listed in this Manual, be sure to request service from the office shown on this Manual or the dealer from whom the product was originally purchased. Attempts to employ procedures other than those specified in this Manual can cause electrical shock, shorting, or fire.
- In the event of a problem that is not described here, be sure to contact the office shown on this Manual or the dealer from whom the product was originally purchased. Careless attempts at repair can result in electrical shock, shorting, or fire.

If a problem occurs, first check to make sure that the wiring connectors are properly connected.

17 TABLE 01

PROBLEM	CAUSE	COUNTERMEASURES
When the main SW is turned ON, the machine is not activated.	The power is not ON.	Firmly insert the plug into the outlet.
	Incorrect power source/voltage.	Make sure that the power supply/voltage are correct.
	The Circuit Protector functioned due to momentary overcurrent.	After eliminating the cause of overload, have the Circuit Protector of the AC Unit restored. <6-6, See 17 FIG. 01.>
	The fuse of the connect board was blown out due to momentary overcurrent.	After eliminating the cause of overload, replace the specified rating fuse. <17 FIG. 01>
Fluorescent lamp inside FL box doesn't light up.	Connector connection fault.	Check connector connections between the Cabinet and the FL box.
	Fluorescent lamp and glow lamp need replacement.	Replace the fluorescent lamp and the glow lamp. <See Chapter 15.>
Sound is not emitted.	Sound volume adjustment is not correct.	Adjust the Switch Unit's sound adjustment volume. <See Chapter 9.>
	Faulty connections for various connectors.	Check the connections for the game board, amp, speakers and Volume connectors.
	Malfunctioning BD, amp and speaker.	Perform Sound Test. <See System Test Mode in LINDBERGH Service Manual.>

Sounds are emitted and the lamps are lit, but the screen is black.	Faulty connections for the visual signal connector or the monitor power connector.	Check the connections for the monitor and game board connectors.
	Broken monitor.	Contact the company from whom the unit was purchased.
Irregular/uneven colors on the monitor screen.	Magnetization to the CRT.	Press the Demagnetization switch on the switch unit. <See Chapter 9.>
Colors on the monitor screen are strange.	Faulty connection for the visual signal connector.	Check the visual signal connector connection and make sure it is secured properly.
	Screen adjustment is not appropriate.	Make adjustment appropriately. <See Chapter 14.>
The on-screen image sways and/or shrinks.	The power source and voltage are not correct.	Make sure that the power supply and voltage are correct.
Does not accept input from any switch or volume.	Faulty connector connections.	Check the connection for the I/O Board and Cabinet connector.
		Check the power for the I/O Board.
Does not accept input from the Shift Lever.	Faulty connector connections.	Check the connections for the connectors in the Control Panel and between the Control Panel and the Cabinet.
	Broken Microswitch.	Replace the Microswitch. <Microswitch 509-5704>
Steering (Servomotor) response is incorrect.	Incomplete power on check.	Power on and verify that the power on check completes properly. <See Section 6-5.>
	Deviation of the volume value.	Adjust the volume value in the Test Mode. <See Chapter 9.>
	Volume gear engagement fault.	Adjust the engagement of the gear. <See Chapter 9, 10.>
	Volume malfunctioning.	Replace the volume. <See Chapter 10.>
	Detached wires.	Check for faulty wire connections around moving parts. When replacing wires, secure them so that they do not touch any moving parts.
No response from Steering (Servomotor).	Failure of power-on checking procedure.	Reconnect the power and complete a power-on checking procedure. <See Section 6-6.>
	Faulty connector connections.	Check the connections for the connectors between the Game Board and Servodriver and between the Servodriver and the Servomotor.
	Thermal element in the Servodriver is operating.	Occurs when the internal temperature reaches 70°C (158°F) and corrects automatically when the unit cools.
	Momentary overload caused a fuse on the Servodriver to blow.	Contact the company from whom the unit was purchased.
Steering (Servomotor) is weak in its force feedback.	Aging of the force feedback mechanism.	Reset in the Test Mode. <See Chapter 9.>

The accelerator or brake does not perform appropriately.	Incorrect volume setting.	Adjust the volume value in the Test Mode. <See Chapter 9.>
	Faulty Volume attachment or adjust gear alignment.	Adjust the volume attachment and verify in Test Mode. <See Chapter 9, 12.>
	Faulty connector connection.	Check the connections for the accelerator and brake connectors and the connectors between the accelerator, brake and cabinet.
	Failure of the volume.	Replace the volume. <See Chapter 12.>
Start button and View Change button input does not work and they do not flash.	Faulty connector connections.	Check the connections for the connectors between the I/O Board, the cabinet and the control panel and those inside the control panel.
Start button and View Change button input works, but they do not flash.	Unverified settings or operation.	The Start button only flashes when Free Play is set. Check the operation in Test Mode. <See Chapter 9.>
	The lamp is burnt out.	Replace the lamp. <See Chapter 15.>
Failure of the network play.	Network play is wrongly set.	Reset correctly. <See Chapter 9, 19.>
	Communication cables are disconnected. Communication cables are wrongly connected.	Reconnect the cables. <See Chapter 19.>
	Damage of communication cables.	Reconnect the cables correctly. Replace the cables. Contact the company from whom the unit was purchased.

Circuit Protector

Functions due to the activation of bimetal. To restore the function, wait for approximately one minute or longer until the bimetal cools off. (Press the Button.)

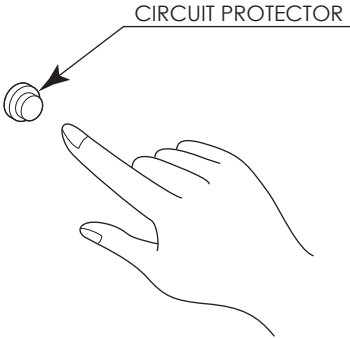

17 FIG. 01

Replacing Fuses

⚠ WARNING

- In case fuse replacements other than those stated in this manual are necessary, contact where you purchased the product from for inquiries regarding this matter.
- In order to prevent an electric shock, be sure to turn power off and unplug from the socket outlet before performing work by touching the internal parts of the product.
- Be careful so as not to damage wirings. Damaged wiring can cause electric shock and short circuit accidents.
- Be sure to use fuses meeting specified rating. Using fuses exceeding the specified rating can cause fire and electric shock accidents.
- After eliminating the cause of the blowing of fuse, replace the fuse. Depending on the cause of fuse blowing, continued use with the fuse as is blown can cause generation of heat and fire hazard.

Fuses are located on the top of the connector board inside the cockpit base. Lower the seat and remove the tower bracket and base lid F to replace fuses.

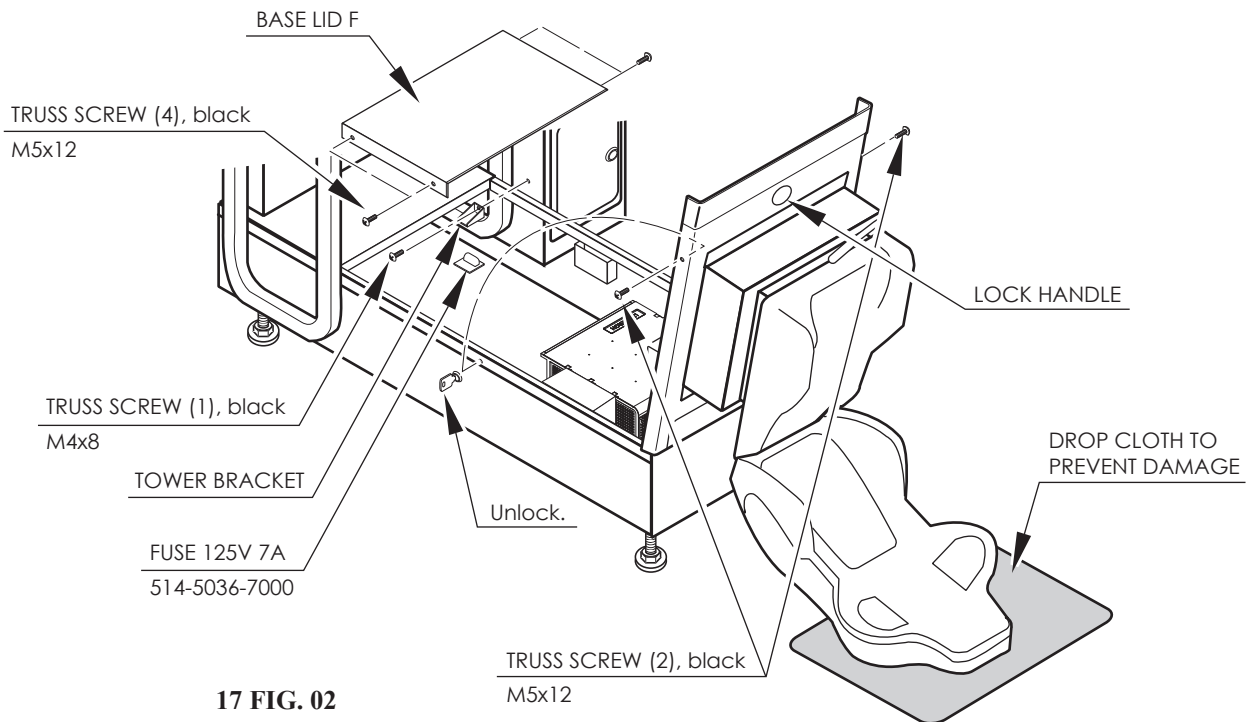

17 FIG. 02

17-2 ERROR MESSAGES

This product displays the following messages when it detects an error. Read the error description and follow the steps indicated. Refer to the LINDBERGH Service Manual for details on error messages displayed with the LINDBERGH logo.

Error 11

JVS I/O board is not connected to main board.

The I/O board and the LINDBERGH have been disconnected.
Check to make sure the I/O board and the LINDBERGH are properly connected.

Error 12

JVS I/O board does not fulfill the game spec.

The number of I/O boards are not sufficient to run the application.
Check to make sure the I/O board and the LINDBERGH are properly connected.

Error 15

Game Program Not Found.

The key chip intended for the application is not connected or is loose.
Check to make sure the key chip and the LINDBERGH are properly connected.

Error 1000

Network is Disconnected.

Communication has been broken.
This occurs when the packet does not arrive in a specific amount of time.
Check to make sure the network devices of all the cabinets are properly connected.
See the NOTE below.

Error 1001

MAIN-Cabinet Not Found.

The main cabinet (CABINET ID 1) was not found when the application was started or a timeout occurred while waiting for communication. Communication will time out after approximately 2 minutes.
- In GAME TEST mode, check to make sure the main cabinet (CABINET ID 1) is properly set up.
- In the case of a time out, turn the power to all the connected cabinets off and then on again.

Error 1002

SUB-Cabinet Not Found.

The sub cabinets (CABINET ID 2-4) were not found when the application was started or a timeout occurred while waiting for communication. Communication will time out after approximately 2 minutes.
- In GAME TEST mode, check to make sure the sub cabinets (CABINET ID 2-4) are properly set up.
- In the case of a time out, turn the power to all the connected cabinets off and then on again.

Error 1003
Same CabinetID Found.

The connected cabinets have the same CABINET ID.
In GAME TEST mode, set the CABINET IDs making sure that they are all different.

Error 1004
Network has not been initialized.

The network has not been initialized.
Check to make sure the network device on the LINDBERGH is functioning properly.

Error 1005
Network cannot use.

The network cannot be used.
Check to make sure the network device on the LINDBERGH is functioning properly.

NOTE: This game is set up so that if one cabinet comes up with the message, "Error 1000 Network is Disconnected," the same message will appear on all the other cabinets as well. To recover the connection, check the network devices connecting the cabinets, and then turn the power off to all the cabinets showing the error and then on again.

18 GAME BOARD

WARNING

- When working with the product, be sure to turn the power off. Working with the power on may cause an electric shock or short circuit.
- Be careful not to damage the wires. Damaged wires may cause an electric shock, short circuit or present a risk of fire.
- Do not use this product with connectors other than those that were connected and used with the game board at the time of shipping. Do not carelessly connect wires to connectors that were not used at the time of shipping, as this may cause overheating, smoke or fire damage.

CAUTION

In this product, setting changes are made during the test mode. The game board need not be operated. Use the game board, etc. as is with the same setting made at the time of shipment so as not to cause electric shock and malfunctioning.

IMPORTANT

Static electricity from your body may damage some electronics devices on the IC board. Before handling the IC board, touch a grounded metallic surface so that the static electricity can be discharged.

18-1 REMOVING THE GAME BOARD

WARNING

- When returning the game board after making repairs or replacements, make sure that there are no errors in the connection of connectors. Erroneous connections can lead to electrical shock, short circuits or fires.
- When connecting a connector, check the direction carefully. Connectors must be connected in only one direction. If indiscriminate loads are applied in making connections, the connector or its terminal fixtures could be damaged, resulting in electrical shock, short circuits or fires.

- 1 Switch off the main unit.
- 2 Remove one truss screw from both right and left sides of base lid.
- 3 Unlock the base using the Master Key.
- 4 Turn the Lock Handle on the base lid Right to unlock the lid.
- 5 Place a drop cloth on the floor behind the the seated area of the machine to prevent damage to the back of the seat when open, carefully lift the lid and slowly lower the back of the seat until it touches the floor.

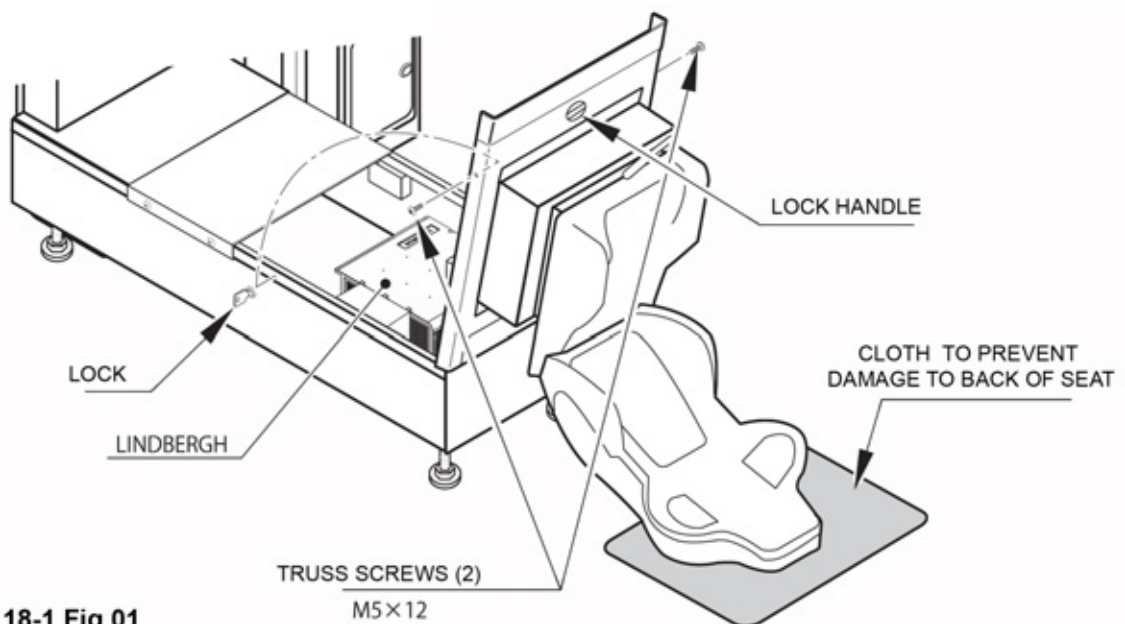

18-1 Fig 01

18-1 REMOVING THE GAME BOARD

- 6** Remove all connectors fitted to the LINBERGH Game Board. Care should be taken, 'Do Not' pull on the wiring in order to disconnect the plug or sockets as this could damage their terminations. Some of the connectors may be secured by screws..

REMOVE ALL CONNECTORS

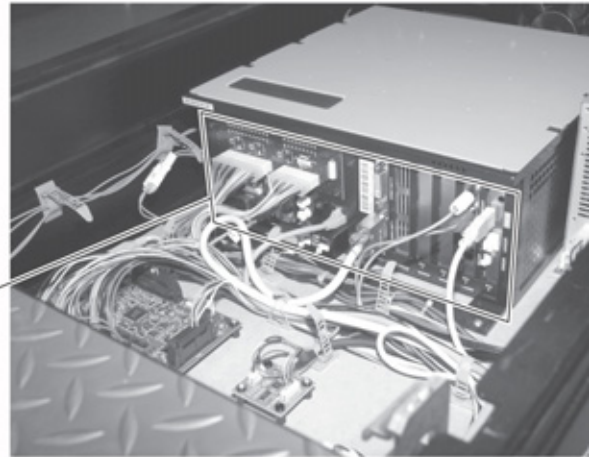

18-1 Fig 02

- 7** Once the harness has been disconnected from the Game Board, the 4x M4 Screws can be removed (1 from each corner) and the LINBERGH can then be lifted from the machine.

4x M4x16 SCREWS, fitted with FLAT & SPRING WASHERS

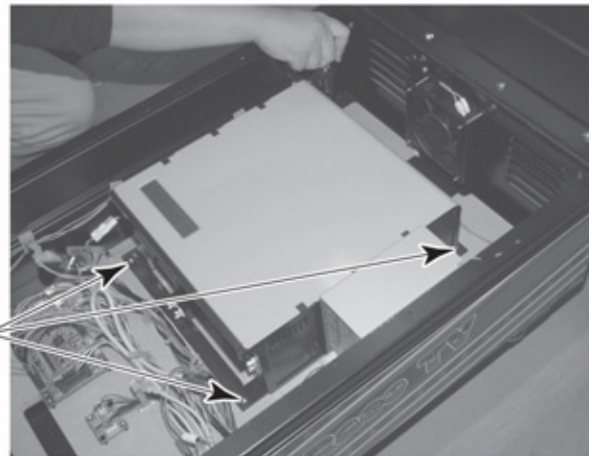

18-1 Fig 03

18

GAME BOARD

18-2 COMPOSITION OF GAME BOARD

STOP IMPORTANT

- With the key chip inserted into it, this board serves as a special-purpose game board for the product.
- Use with the dip switches (DIP SW) on the board at the prescribed settings. If settings do not match the product, an error message will be displayed. In some cases, the game cannot be started.

ASSY CASE LBG L 1GB RTV (844-0019D)

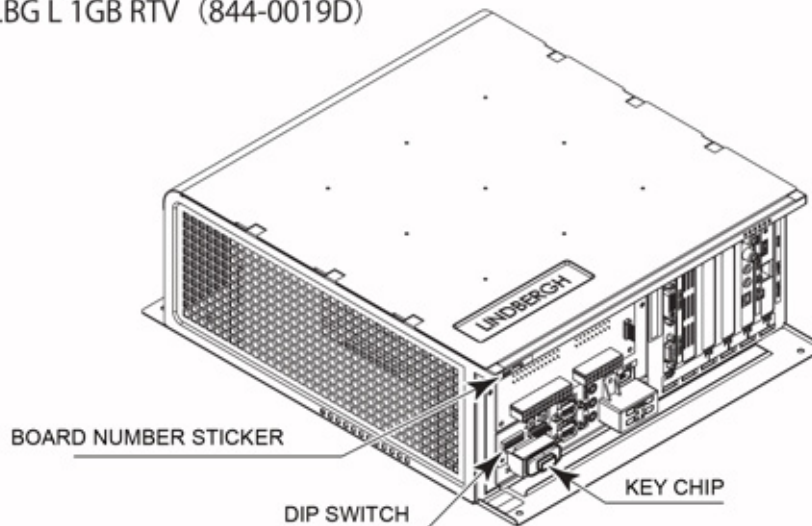

18-2 Fig 01

DIP SWITCH SETTINGS



18-2 Fig 02

19 COMMUNICATION PLAY

For this game, up to 4 machines can be connected to allow up to 4 players to play simultaneously. In this instance, connecting the communication cable and setting for the communication play are required.

19-1 INSTALLATION PRECAUTIONS

WARNING

- Before starting to work, ensure that the Power SW is OFF. Failure to observe this can cause electric shock or short circuit.
- Use care so as not to damage wirings. Damaged wiring can cause electric shock or short circuit.
- Do not touch undesignated places. Touching places not designated can cause electric shock or short circuit.
- The work described below should be carried out by the site maintenance personnel or other qualified professional. Work carried out by personnel without the necessary skill or technology can cause accident.
- To perform work safely and avoid serious accident such as the cabinet falling down, do not perform work in places where step-like grade differences, a ditch, or slope exist.
- To prevent accidents while working or while operating the product after it has been installed, be sure not to conduct any procedures other than those given in this manual. There are cases in which procedures not covered in this manual require special tools and skills. If a procedure not given in this manual is required, request service from the office given in this manual or from the point of purchase.

CAUTION

- To perform work safely, be sure to secure the space corresponding to number of machines to be linked. Failure to observe this can cause accident.
- To avoid accidents, use a cable cover that will not cause patrons to trip when laying network cables in areas of heavy foot traffic.
- To prevent accidents and acts of vandalism, cover the network cables with the strongest cover possible.

Since 2 or more machines are to be linked, sufficient power corresponding to the number of machines used need to be supplied. Note that as a standard, the per machine capacity should be 7 A for the 100-120 V area, and 4 A for the 220-240 V area.

Distance between Machines

The maximum distance between the game machines depends on the length of the cables connecting them, but make sure the units are separated from each other by at least 70 cm (27.6 in) so that players can pass between them. Do not install more than the designated number shown in the layout diagram.

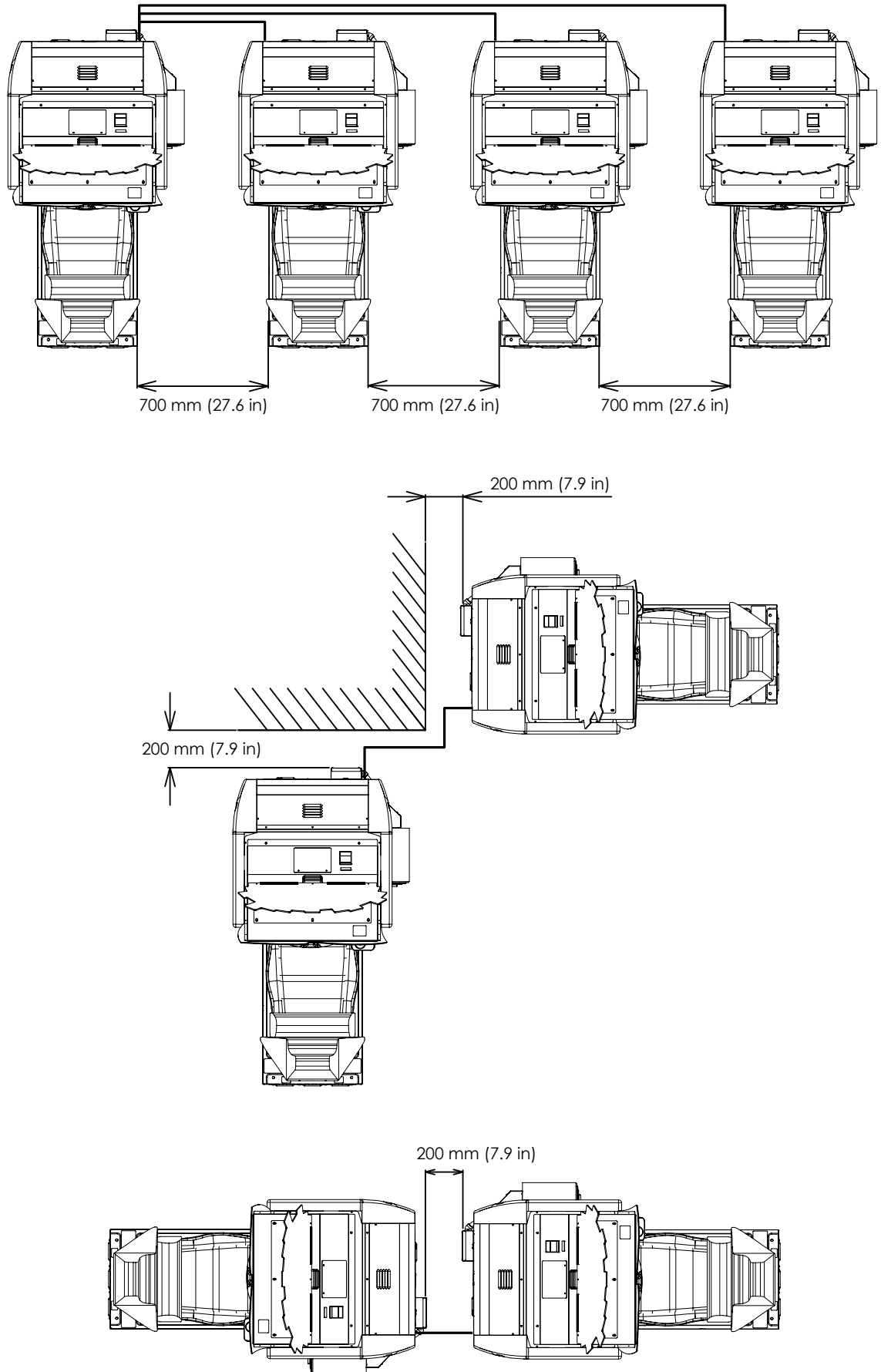

19-1 FIG. 01

19-2 CONNECTING THE COMMUNICATION CABLE

To enable network play, the hubs inside each of the game machines involved must be connected with network (LAN) cables.

Connect the hub inside one of the machines to the hubs in each of the other machines using LAN cables. There is no need to connect the other machines to each other.

Do not connect LAN cables to game machines when they are not used for network play.

- 1 Turn off the power and unplug the power cord from the outlet.
- 2 Using Chapter 7 of this manual as reference, move the machines so that they are lined up. Leave enough space on the back lid side of the machine to perform the rest of the operations in this procedure.
- 3 The edge holders (the holes through which the LAN cables are threaded) are located on the left and right sides of the lower back lid. Decide how the LAN cables should be threaded according to the layout of the machines. To reach the edge holders, loosen 2 of the screws on the cable cover and slide the cover aside.

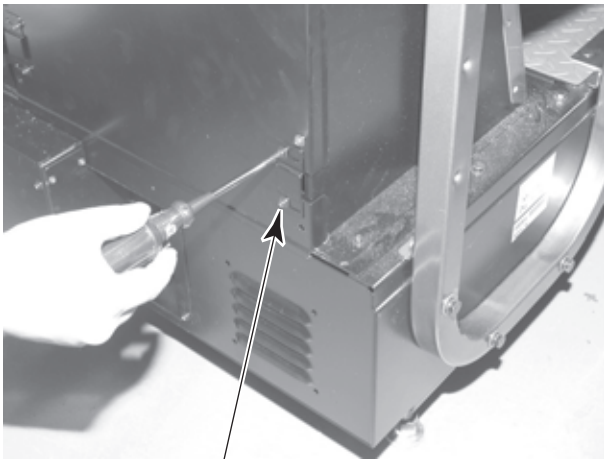

19-2 FIG. 01

SCREW (2), black
M4x8, w/flat & spring washers

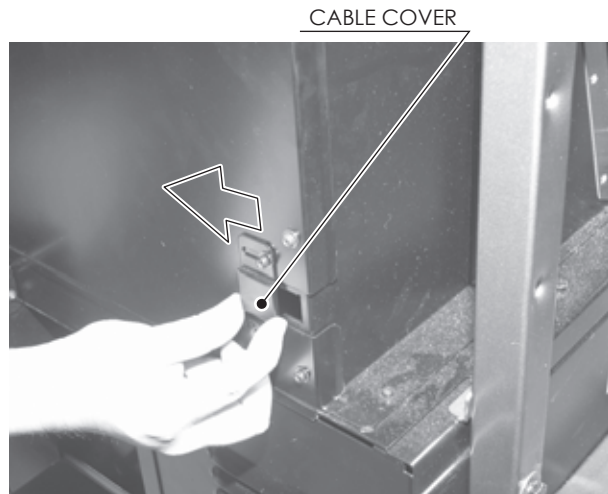

19-2 FIG. 02

CABLE COVER

- 4 Tighten the 2 screws firmly to secure the cable cover in place.

SCREW (2), black
M4x8, w/flat & spring washers

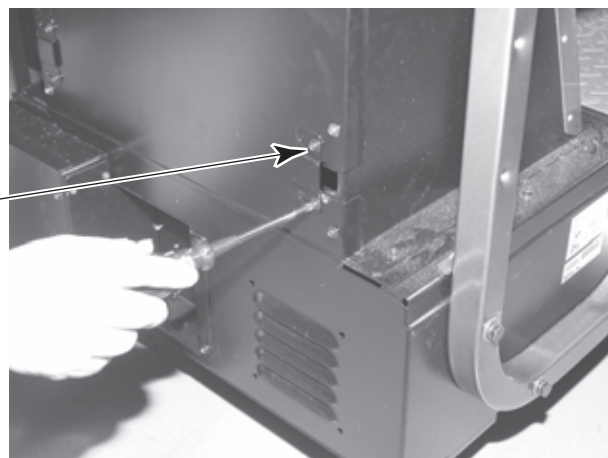

19-2 FIG. 03

5 Remove the 6 screws from the lower back lid and then remove the lid.

SCREW (6), black
M4x8, w/flat & spring washers

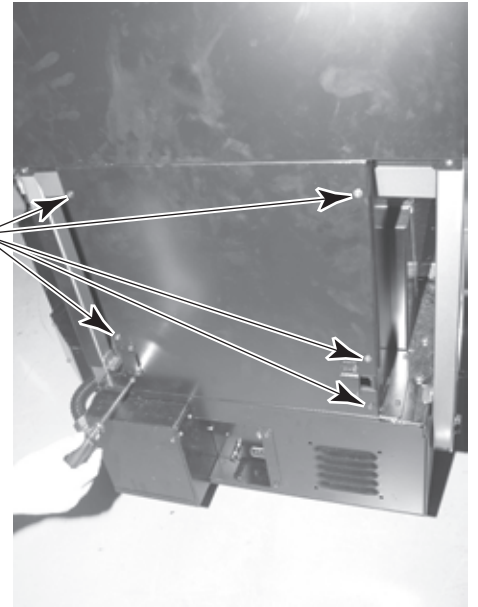

19-2 FIG. 04

LOWER BACK LID



19-2 FIG. 05

6 Pass the LAN cable through the edge holder (the rectangular frame-shaped plastic part.) Pressing down on the edge holder from above will cause it to stretch elastically and open up.

EDGE HOLDER



19-2 FIG. 06

-
- 7** Insert the communication cable connector into one of the open ports. Port 1 on the hub is connected to the game board inside the base.

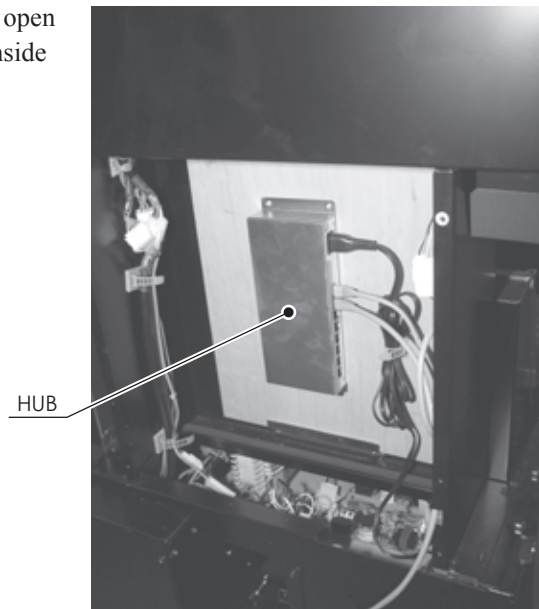

19-2 FIG. 07

-
- 8** Attach the lower back lid with the 6 screws.

-
- 9** Once the machines have been linked for network play, line them up. Leave as much space as possible between the machines.

19-3 NETWORK PLAY SETTINGS

Each of the linked machines must be set up for network play. If the machines are not set up correctly, network play will not be possible.

For this game, up to 4 machines can be connected to allow up to 4 players to play simultaneously.

- 1 Turn on the power on each machine to be used in network play.
- 2 Cause all of the machines to enter the Test Mode.
- 3 Select the GAME TEST MODE and press the Test button to display the GAME TEST MENU screen.
- 4 Select the GAME ASSIGNMENTS in the GAME TEST MENU screen and press the Test button.

GAME ASSIGNMENTS	
CABINET ID	XXX
GAME DIFFICULTY	NORMAL
CONTINUE	ON
ADVERTISE SOUND	ON
COMMENTARY VOLUME	HIGH
NUM OF LAPS	3
HEAT	1
DRESS CODE	LOW
SPEEDOMETER	KM/H
CASUAL USER MODE	OFF
-> DEFAULT SETTING	
EXIT	

19-3 FIG01 GAME ASSIGNMENTS Screen

- 5 Perform the CABINET ID setting. Set the different ID number to each machine. Be sure to assign one of them with the ID number of "1."
- 6 Cause all of the machines to exit from the TEST MODE. Always select EXIT in the SYSTEM TEST MENU screen.

19-4 NETWORK PLAY PRECAUTIONS

STOP IMPORTANT

- In network play, difficulty level and other settings are made from CABINET ID Number 1. Changing the settings at CABINET ID Number 1 also changes the settings for other units.
- If one of the units attached for network play enters Test Mode, the other unit will display the Error screen.
- Even when units are connected for network play, each seat, each game may be given different cost settings. Incorrect cost settings may cause budget balancing problems.

The operation of a unit when connected to other units for network play is different than that of a stand-alone unit. Administration of network units should be handled carefully.

Entering Test Mode will cause any other machines set up for network play to display the Error screen. When customers are playing the game, do not enter Test Mode on any network play-enabled machine.

19-5 ATTACHING SATELLITE NUMBER STICKERS

Attach the satellite number stickers to the back of each seat of the cabinets.



SATELLITE NUMBER STICKER

19-5 FIG. 01

20 DESIGN-RELATED PARTS

For the warning display stickers, refer to Section 1.

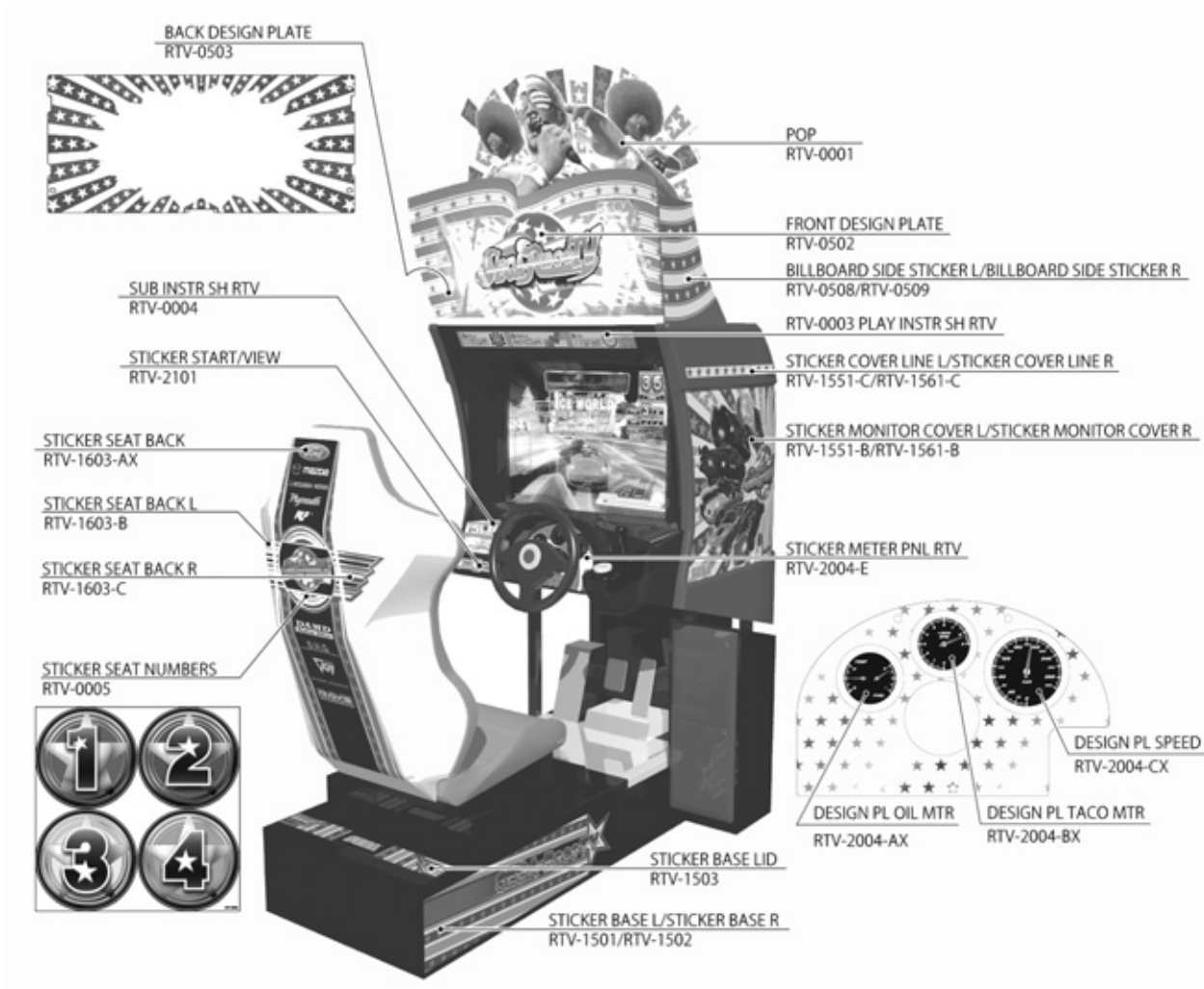

PLEASE NOTE:

The illustration above shows that of a different model built in Europe. When ordering spares, please place the letters "UK" after the part number.

21 PARTS LIST

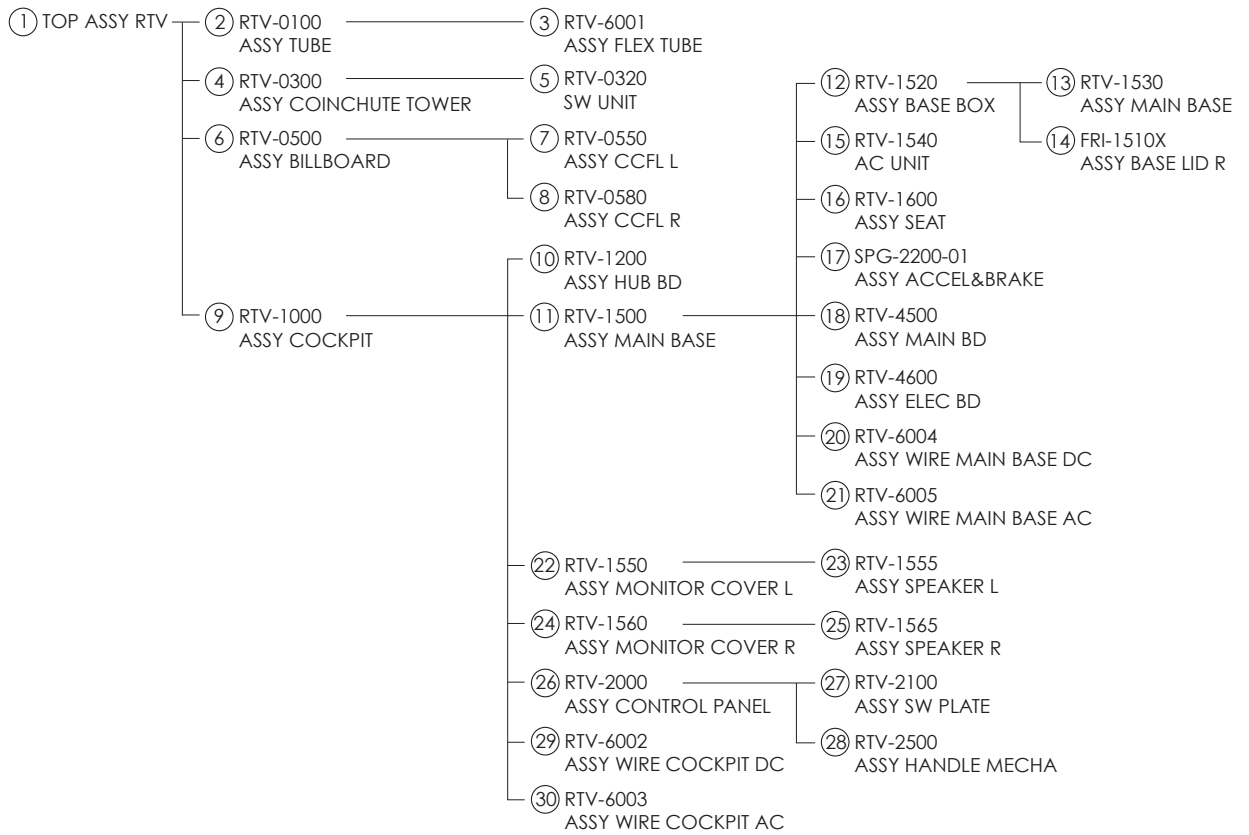

RACE TV TWIN BOM STRUCTURE

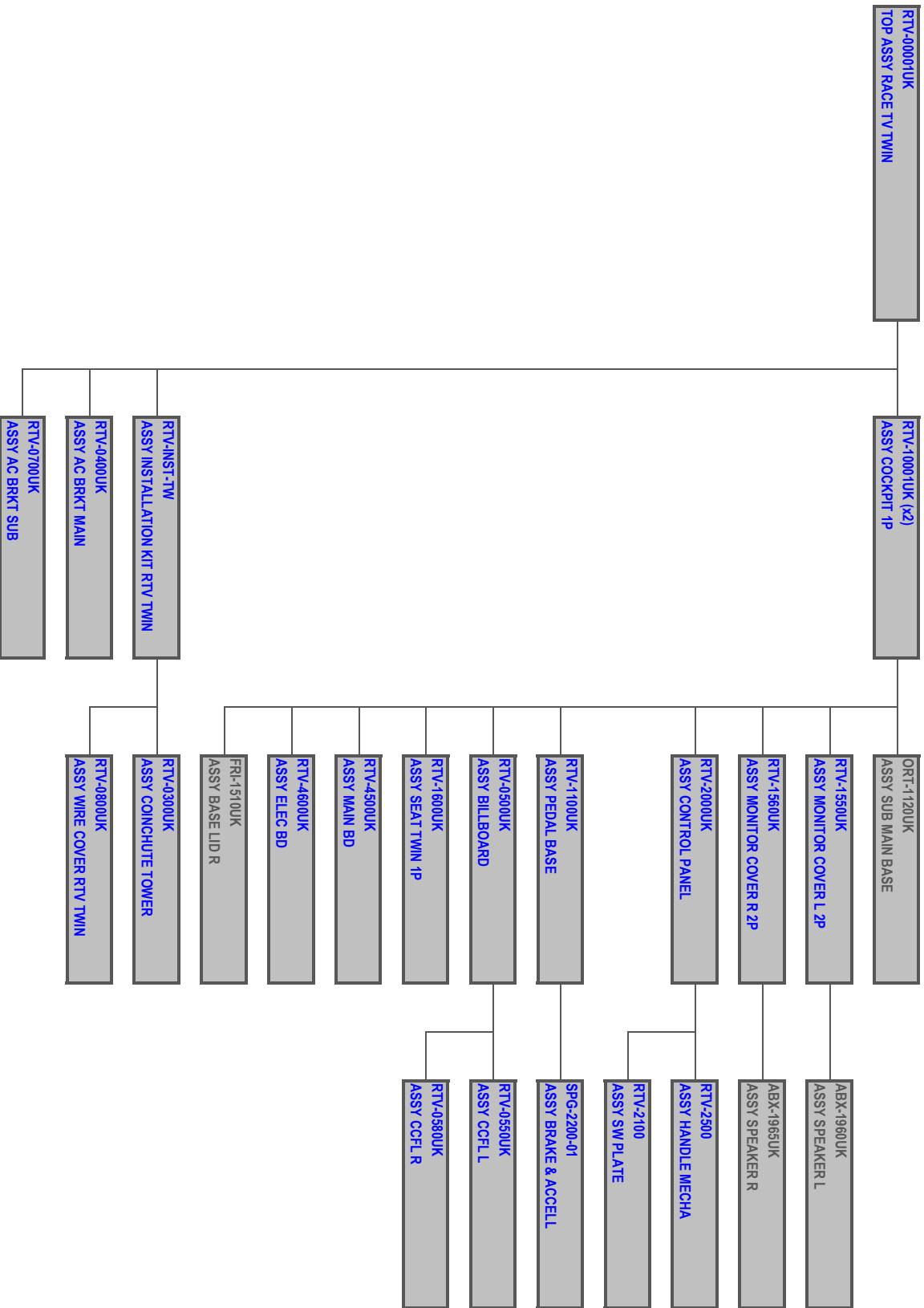

① TOP ASSY RTV

(D-1/2)

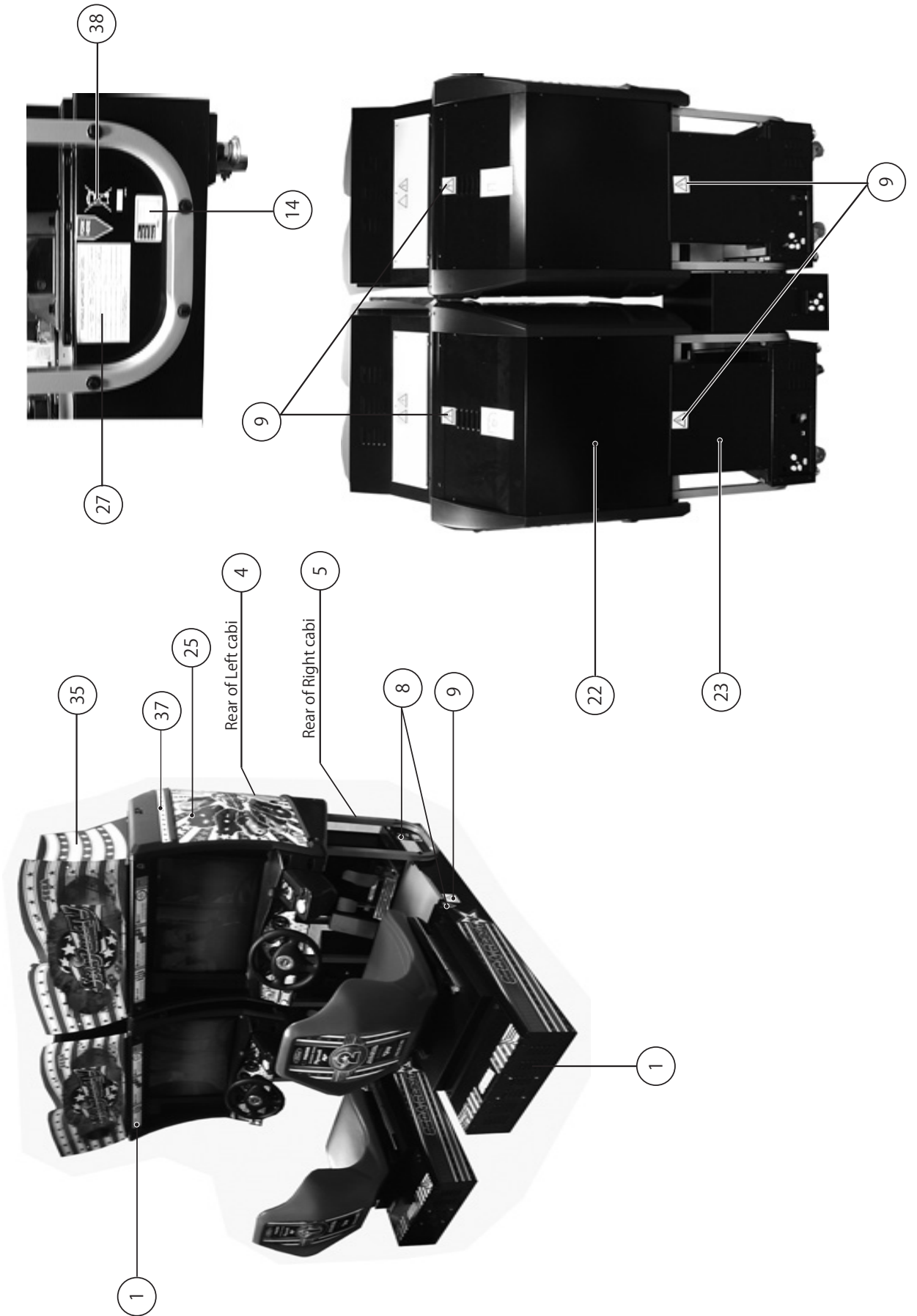

1 TOP ASSY RTV

(D-2/2)

ITEM NO.	PART NO.	DESCRIPTION	NOTE
1	RTV-10001UK	ASSY COCKPIT 1P	
3	RTV-INST-TW	ASSY INSTALLTION KIT	NOT SHOWN
4	RTV-0400UK	ASSY AC BKT MAIN	REAR OF CABI
5	RTV-0700UK	ASSY AC BKT SUB	REAR OF CABI
8	421-7020UK	STICKER CAUTION FORK	
9	LB1102	STICKER DANGEROUS VOLTAGE	
10	ORT-4552UK	HUB HOLDER BKT	
14	421-7988-91UK	STICKER SERIAL NUMBER UK	
15	421-8543UK	STICKER CABI L UK	
16	421-8544UK	STICKER CABI R UK	
19	RTV-0002	BLIND CAP	
22	INY-0004	BACK LID INY	
23	DYN-0008XUK	BACK LIB B UK	
24	RTV-1551-BUK	STICKER COVER PANEL L	
25	RTV-1561-BUK	STICKER COVER PANEL R	
27	LB1046	LABEL TESTED ELEC SPEC	
28	RAL-XXXX-13UK	LOCK COVER UK	
34	RTV-0508UK	BILLBOARD SIDE STKR L	
35	RTV-0509UK	BILLBOARD SIDE STKR R	
36	RTV-1551-CUK	STICKER LINE L	
37	RTV-1561-CUK	STICKER LINE R	
104	290190	FOAM TAPE 20MMX4.5MM	
201	000-P00412-WB	M4X12 MSCR PAN W/FS BLK	
202	000-P00408-WB	M4X8 MSCR PAN W/FS BLK	
203	010-P00412	M4X12 S-TITE PAN PAS	
204	008-T00408-0C	M4X8 TMP PRF TH CRM	
205	029-B00620-0B	M6X20 SKT BH BLK	
206	060-S00600-0B	M6 WSHR SPR BLK	
207	060-F00600-0B	M6 WSHR FORM A FLT BLK	
212	050-F00400	M4 NUT FLG SER PAS	
301	600-7269-0200UK	CA LAN CAT5 200CM	
304	600-7269-0500UK	CA LAN CAT5 500CM	
401	PK0398	SHRINK WRAP ABX STD	
402	PK0432	PALLET RTV TWIN	

② ASSY COCKPIT (RTV-10001UK)

(D-1/3)

2 PARTS LIST

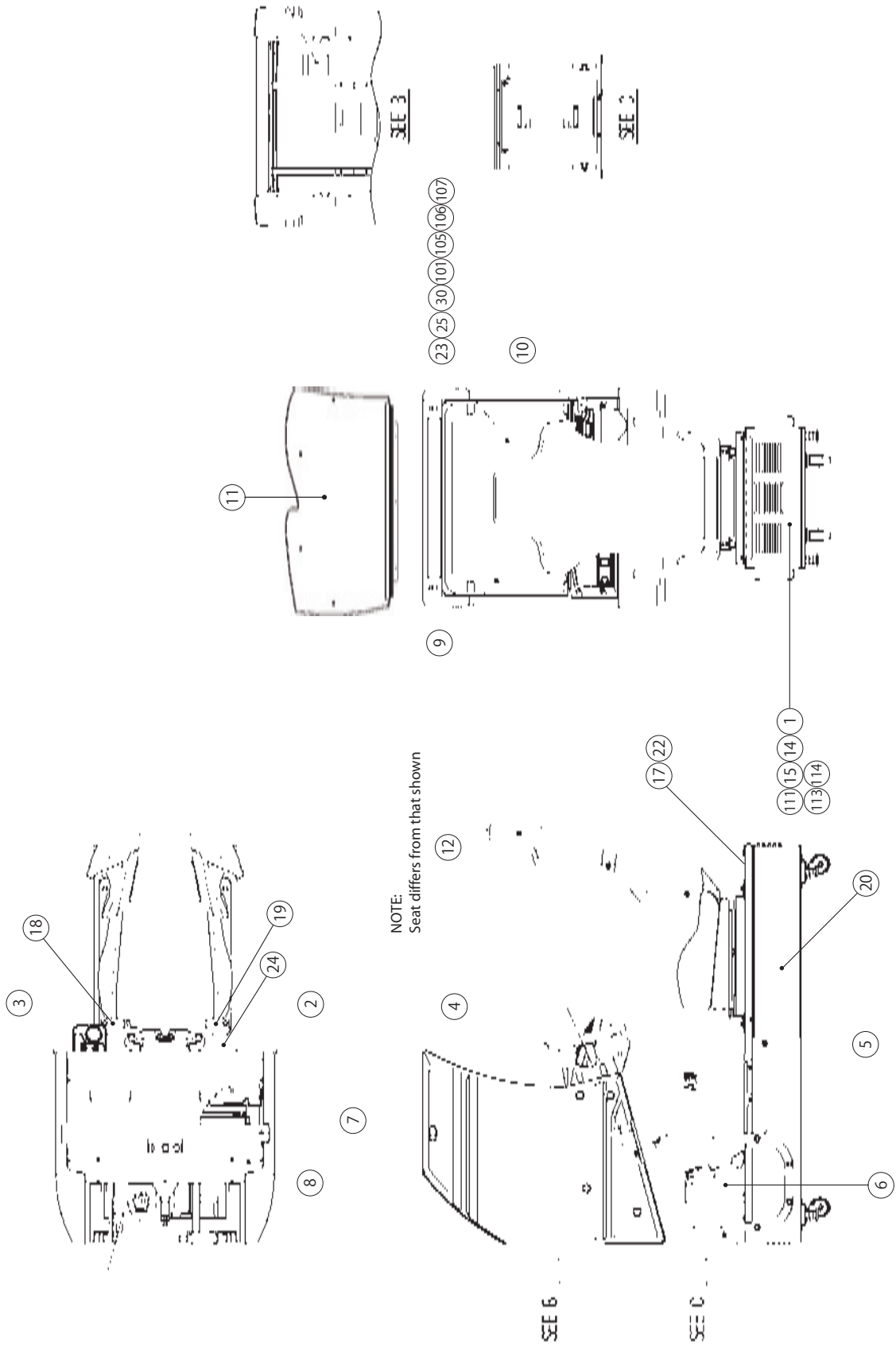

② ASSY COCKPIT 1P (RTV-10001UK)

(D-2/3)

ITEM NO.	PART NO.	DESCRIPTION	NOTE
1	ORT-1120UK	ASSY SUB MAIN BASE	
2	RTV-1550UK	ASSY MONITOR COVER L 2P	
3	RTV-1560UK	ASSY MONITOR COVER R 2P	
4	RTV-2000UK	ASSY CONTROL PANEL	
5	POD-1023UK	MONITOR STAND	
6	RTV-1100UK	ASSY PEDAL BASE	
7	POD-1021UK	MONITOR SUPPORT	
8	RTV-1001UK	ROOF LID	
9	TOF-1010	MONITOR MASK	
10	SPG-1005	MASK HOLDER	
11	RTV-0500UK	ASSY BILLBOARD	
12	RTV-1600UK	ASSY SEAT 1P	
14	RTV-4500UK	ASSY MAIN BD	
15	RTV-4600UK	ASSY ELEC BD	
17	FRI-1510UK	ASSY BASE LID R	
18	RAL-2007X	RUBBER HOLDER R TWIN	
19	RAL-2008X	RUBBER HOLDER L TWIN	
20	RTV-1501UK	STICKER BASE L	
21	RTV-1502UK	STICKER BASE R	
22	RTV-1503UK	STICKER BASE LID	
23	POD-1026UK	CRT SPACER (POD)	
24	DUT-2031UK	FRONT FLOOR UK DUT	
25	SRT-1009UK	MONITOR SPLASH GUARD SRT TW	
26	SRT-2031UK	NEOPRENE RUBBER STRIP 10X3MM	
27	OS1004	DRAFT EXCLDR 4X7MM BLK 10M	
30	440-WS0220K	WARNING STICKER TRAP HAZZARD	
101	200-5949-PFX	ASSY 29" PFX CRT 240V	
105	280-5112	BUSH FOR TV	
106	280-5113	COLLAR FOR TV	
107	068-652516	M6 WSHR FLT 25OD PAS	
108	280-L00716-0S	STANDOFF 7OD 4ID 16L	
109	601-6231-C100	EDGING NEW TYPE	
110	601-6231-D100	EDGING NEW TYPE	
111	260-0011-02	AXIAL FLOW FAN AC100V 50-60HZ	
113	FN1012	MESH GUARD METAL 120MM FAN	
114	OS1195	RIVET SNAP MOSS SR1811	
115	350014	SELF ADH PAD	
116	280-A00748-PM	ROUTER TWIST D7 S04.8PA	
117	280-A02048-PM	ROUTER TWIST D20 S04.8PA	
118	601-0460	CABLE TIE	
201	030-000840-SB	M8X40 BLT W/S BLK	
202	008-B00825-0B	M8X25 TMP PRF BH BLK	
203	060-S00800-0B	M8 WSHR SPR BLK	
204	060-F00800-0B	M8 WSHR FORM A FLT BLK	
205	030-000850-SB	M8X50 BLT W/S BLK	
206	068-852216-0B	M8 WSHR 22OD FLT BLK	
207	030-000616-SB	M6X16 BLT W/S BLK	
208	068-651616-0B	M6 WSHR 16OD FLT BLK	
209	000-P00408-WB	M4X8 MSCR PAN W/FS BLK	
210	000-T00530-0B	M5X30 MSCR TH BLK	
211	000-T00512-0B	M5X12 MSCR TH BLK	
212	068-552016-0B	M5 WSHR 20OD FLT BLK	
213	000-F00512	M5X12 MSCR CSK PAS	
214	030-000820-SB	M8X20 BLT W/S BLK	
215	032-000425	M4X25 W/BLT PAS	
216	068-441616	M4 WSHR 16OD FLT PAS	
217	008-T00512-0B	M5X12 TMP PRF TH BLK	

② ASSY COCKPIT 1P (RTV-10001UK)

(D-3/3)

ITEM NO.	PART NO.	DESCRIPTION	NOTE
218	050-F00600	M6 NUT FLG SER PAS	
219	000-P00320	M3X20 MSCR PAN PAS	
220	012-HB0512	N10X12" S/TAP HEX B PAS	
221	060-F00500	M5 WSHR FORM A FLT PAS	
301	RTV-60017UK	WH AC MONITOR	
302	RTV-60018UK	WH EXT ENCODER	
303	RTV-60019UK	WH EXT MONITOR	
306	RTV-60023UK	WH EXT SIGNAL VIEW & SHIFT	
307	RTV-60024UK	WH EXT SIGNAL BOOST	
308	RTV-60025UK	WH EXT 10 BOARD VOL	
309	RTV-60026UK	WH EXT AMP OUTPUT BASE	
310	RTV-60028UK	WH EXT VIEW & SHIFT	
311	RTV-60029UK	WH EXT SIGNAL BOOST	
312	RTV-60030UK	WH EXT HANDLE MON STAND	
313	RTV-60031UK	WH EXT AMP OP MON STAND	
323	600-9020-44K	WH EARTH 200MM M4/M4 K	
324	600-9100-44K	WH EARTH 1000MM M4/M4 K	
325	600-9020-44K	WH EARTH 200MM M4/M4 K	
326	600-9060-46K	WH EARTH 600MM M4/M6 K	
327	RTV-60043UK	WH EXT SIGNAL CCFL	
328	RTV-60044UK	WH EXT SIGNAL CCFL MON STAND	
329	RTV-60039UK	WH EXT ENCODER BASE	
330	RTV-60040UK	WH EXT MOTOR	
331	RTV-60041UK	WH EXT AC	
332	RTV-60042UK	WH AC FAN	
333	RTV-60104UK	WH CREDIT BTN	
334	600-7009-2500UK	ASSY RGB CA D SUB 15 PIN	

3 ASSY SUB MAIN BASE (ORT-1120UK)

(D-1/1)

ITEM NO.	PART NO.	DESCRIPTION	NOTE
1	DUT-1121UK	MAIN BASE	
6	MA1007	CASTOR SWIVEL 63MM NYLON	
10	601-5699UK-01	LEG ADJ M16X100 1L/NUT	
209	030-000816	M8X16 BLT PAS	
210	060-S00800	M8 WSHR SPR PAS	

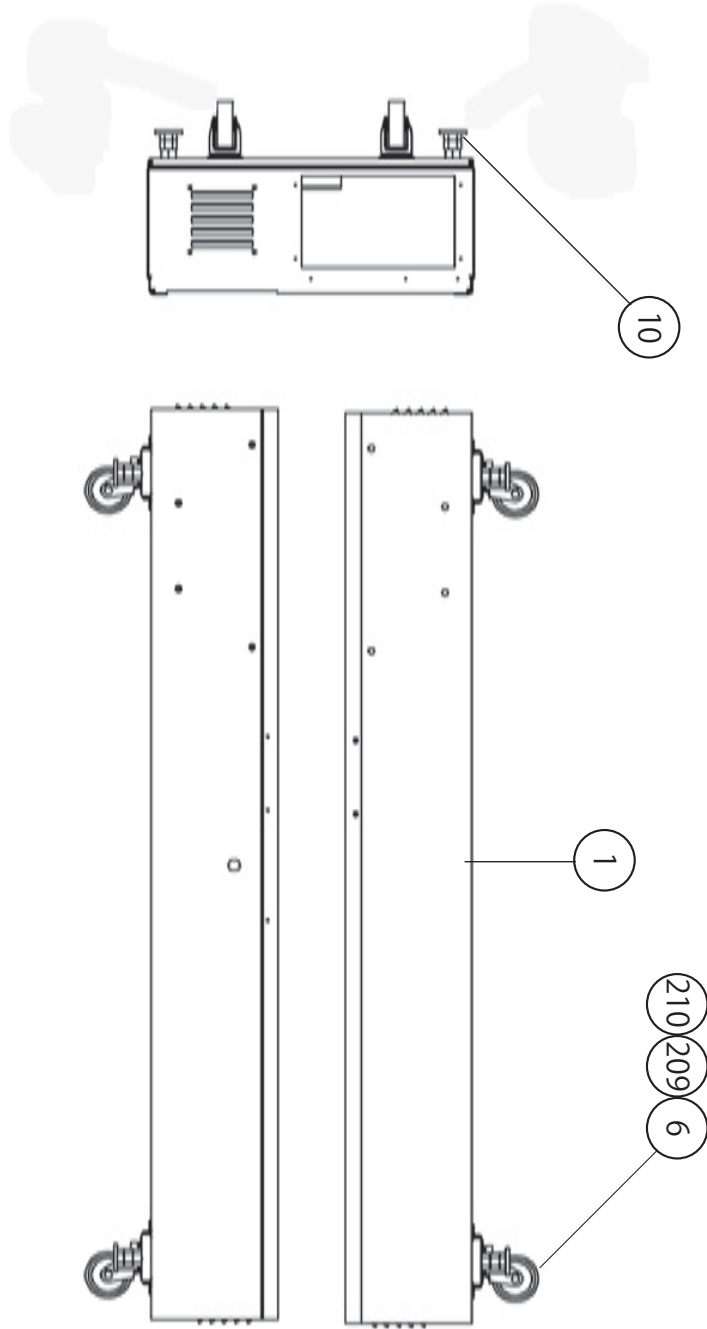

④ ASSY MONITOR COVER L (RTV-1550UK)

(D-1/1)

ITEM NO.	PART NO.	DESCRIPTION	NOTE
1	ABX-1960UK	ASSY SPEAKER L	
2	RTV-1551-A	COVER PANEL BLANK L	
3	DYN-1032UK	MASK BKT	
201	000-P00408-W	M4X8MSCR PAN W/FS PAS	

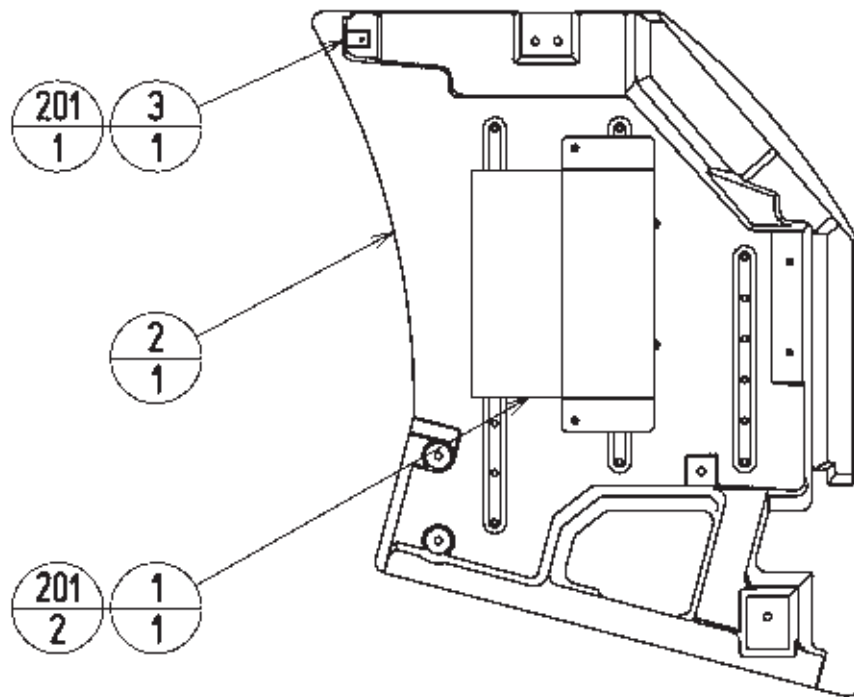

5 ASSY MONITOR COVER R (RTV-1560UK)

(D-1/1)

ITEM NO.	PART NO.	DESCRIPTION	NOTE
1	ABX-1965UK	ASSY SPEAKER R	
2	RTV-1561-A	COVER PANEL BLANK R	
3	DYN-1032UK	MASK BKT	
201	000-P00408-W	M4X8MSCR PAN W/FS PAS	

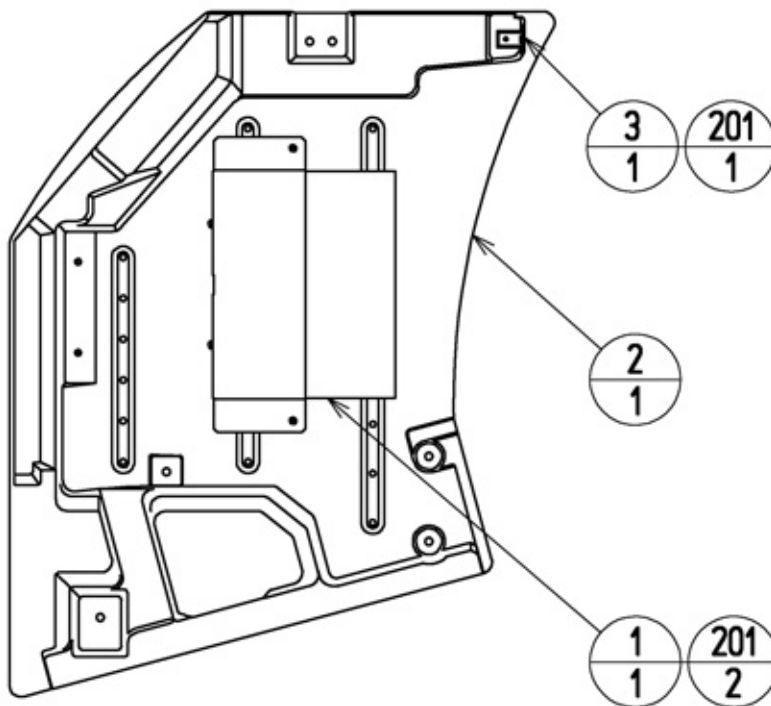

⑥ ASSY CONTROL PANEL & HANDLE MECHA (RTV-2000UK)

(D-1/2)

ITEM NO.	PART NO.	DESCRIPTION	NOTE
1	SPG-2001X	STEERING WHEEL	
2	DYN-1209X	HANDLE COLLAR	
3	SPG-2002	STEERING EMBLEM	
4	RTV-2004	CONTROL PANEL COVER	
5	RTV-2001UK	CONTROL PANEL BKT TWIN	
6	RTV-2003	SHIFT COVER INY (UPPER)	
7	DYN-1223X	SHIFT COVER B	
9	RTV-2002UK	SHIFT BASE	
10	RTV-2500	ASSY HANDLE MECHA	
11	610-0408-01	UP/DOWN SHIFT AL YL	
12	RTV-2100	ASSY SW PLATE	
13	SPG-2039	SPACER RING	
15	117-5164UK	PLATE START 37X42 UK	
16	DYN-0010UK	DENOMI PLATE	
102	280-A01200-A	ROUTER TWIST D12	
103	280-A02000-A	ROUTER TWIST D20	
104	280-02-48-PM	ROUTER TWIST D20 PAN LG	
108	509-5440	PUSH BTN SW IT GRN W/L DC 14V	
109	509-6175	SW OBSA-60UMQ/BOOST RTV	
201	020-000820	M8X20 BLT PAS	
202	060-F00800	M8 WSHR FORM A FLT PAS	
203	060-S00800	M8 WSHR SPR PAS	
204	050-U00800	M8 NUT NYLOK PAS	
205	FAS-200013	M4X16 SKT CAP CRM	
206	000-T00416-0B	M4X16 MSCR TH BLK	
207	000-P00412-W	M4X12 MSCR PAN W/FS PAS	
208	008-T00516-0B	M5X16 TMP PRF TH BLK	
209	000-P00312-W	M3X12 MSCR PAN W/FS PAS	
210	030-000820-S	M8X20 BLT W/S PAS	
211	050-F000300	M3 NUT FLG SER PAS	
212	000-T00412-0C	M4X12 MSCR TH CRM	
215	050-F00400	M4 NUT FLG SER PAS	
216	000-T00416-0B	M4X16 MSCR TH BLK	
301	RTV-60015UK	WH ENCODER	
302	RTV-60016UK	WH MOTOR	
303	RTV-60033UK	WH SIGNAL VIEW HANDLE MECHA	
304	RTV-60034UK	WH EXT SHIFT HANDLE MECHA	
305	RTV-60035UK	WH SIGNAL SHIFT HANDLE MECHA	
306	RTV-60036UK	WH SIGNAL BOOST HANDLE MECHA	
307	RTV-60037UK	WH VOL HANDLE MECHA	

⑥ ASSY CONTROL PANEL (RTV-2000UK)

(D-2/2)

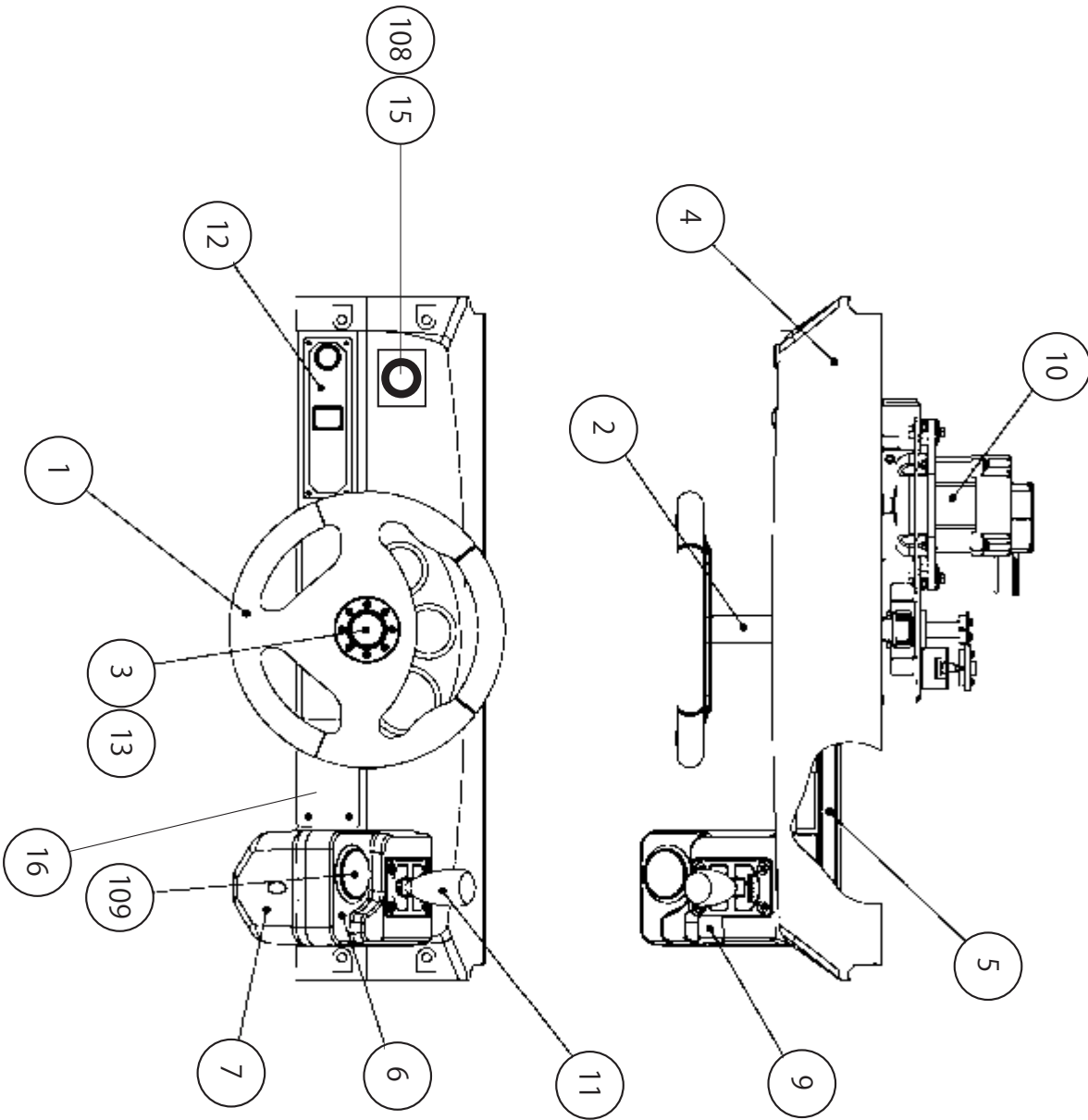

⑦ ASSY HANDLE MECHA (RTV-2500)

(D-1/2)

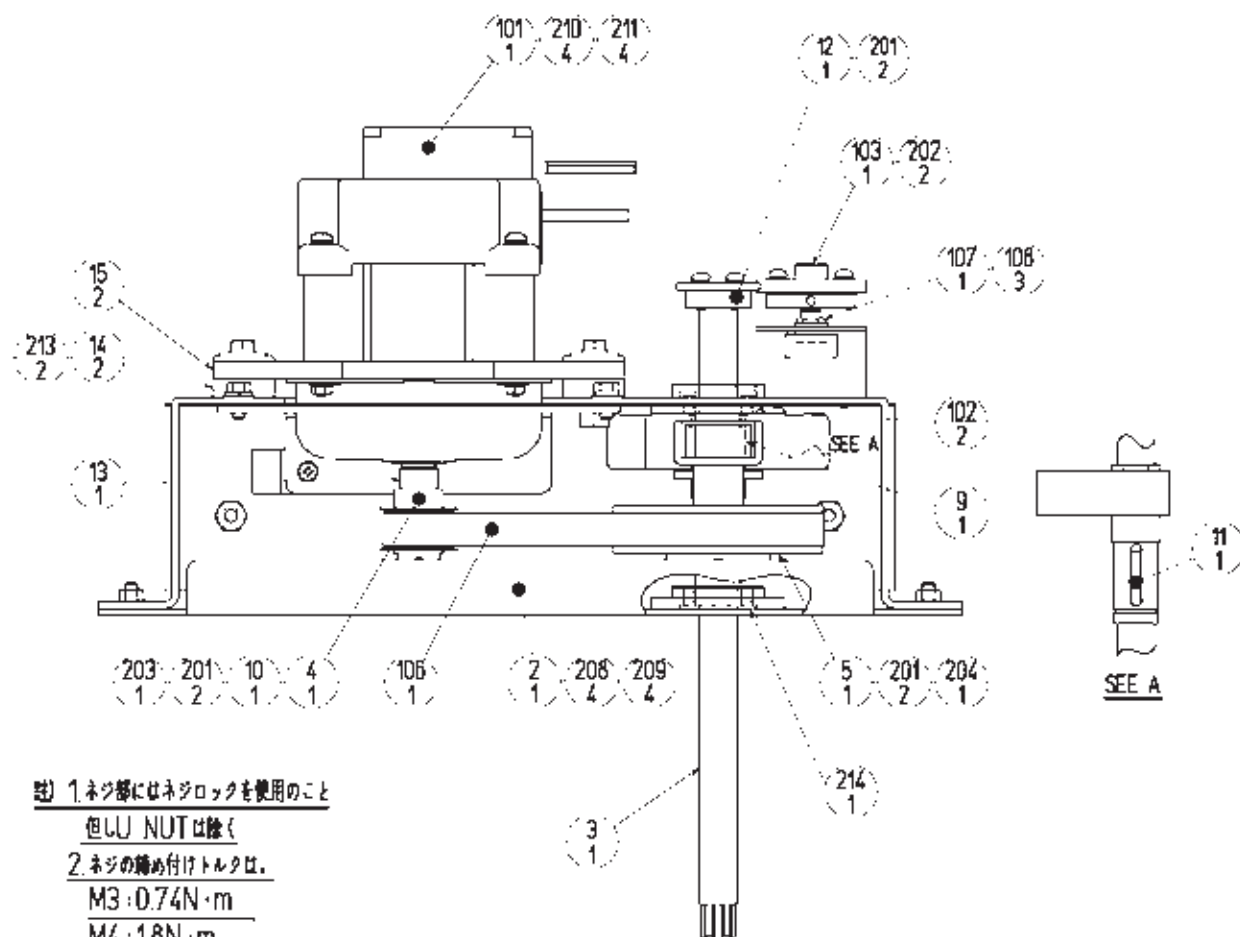
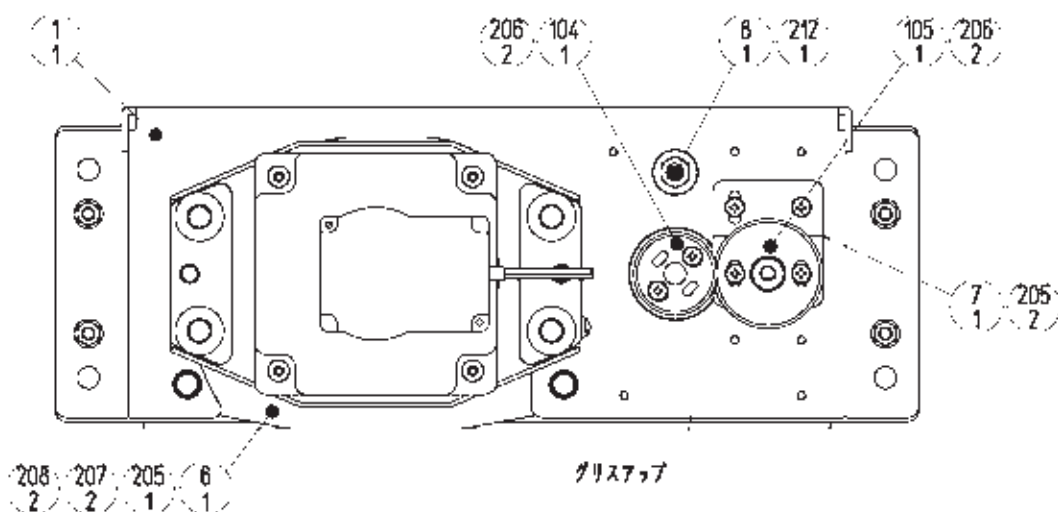

註) 1.ネジ部にはネジロックを使用のこと
但し NUTは除く

2.ネジの締め付けトルクは、

M3:0.74N・m

M4:1.8N・m

M6:5.6N・m

M8:17.4N・m

M8:20.0N・m

3.モーターシャフトの位置は、ハンドルシャフトセンター時

キー溝が上側±45°に来るように取付のこと

4.タイミングベルトS5M 初張力 95~165[N]

スパン=130[mm] ベルト幅=15[mm]

単位質量=0.034[kg/(10mm幅×1m長さ)](三ツ星)

単位質量=0.039[kg/(10mm幅×1m長さ)](バンドー)

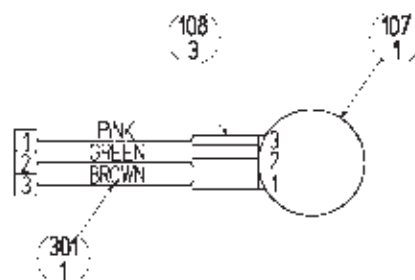

7 ASSY HANDLE MECHA (RTV-2500)

(D-2/2)

ITEM NO.	PART NO.	DESCRIPTION	NOTE
1	ORA-2501	HANDLE BASE	
2	SPG-2502	BASE LID	
3	ORA-2502	HANDLE SHAFT	
4	SPG-2504	PULLEY 20 S5M	
5	SPG-2505	PULLEY 60 S5M	
6	ORA-2503	MOTOR BRKT	
7	ORA-2504	VR BRKT	
8	ORA-2505	STOPPER BOLT	
9	ORA-2506	STOPPER RUBBER	
10	SPG-2453	KEY 4x4x40	
11	DYN-1270	STOPPER KEY	
12	SLC-1130	ADJUST RING	
13	ORA-2507	MOTOR SHAFT COLLAR	
14	253-5592	MOTOR INSULATOR A	
15	253-5593	MOTOR INSULATOR B	
101	350-5805-02	SERVO MOTOR W/FG SIDE TYPE	
102	100-5112	BEARING 17 (NSK 6003ZZ)	
103	601-8966	GEAR HOLDER	
104	601-6172	GEAR 48	
105	601-6959	GEAR 64	
106	601-9173	TIMING BELT (150 S5M 475)	
107	220-5484	VOL CONT B-5K OHM	
107	220-5753	VOL CONT B-5K OHM (TOCOS)	
108	310-5029-F20	SUMITUBE F F 20MM	
201	028-A00408-P	SET SCR HEX SKT CUP P M4x8	
202	028-A00308-P	SET SCR HEX SKT CUP P M3x8	
203	065-S012S0-Z	STP RING BLK OZ S12	
204	065-S020S0-Z	STP RING BLK OZ S20	
205	000-P00408-W	M SCR PH W/FS M4x8	
206	000-P00412-W	M SCR PH W/FS M4x12	
207	030-000612-S	HEX BLT W/S M6x12	
208	060-F00600	FLT WSHR M6	
209	050-U00600	U NUT M6	
210	030-000840-S	HEX BLT W/S M8x40	
211	068-852216	FLT WSHR 8.5-22x1.6	
212	060-S01200	SPR WSHR M12	
213	012-P00412	TAP SCR #2 PH 4x12	
214	FAS-650023	WAVE WSHR 26.4-34.2x0.3	
301	600-6866-01	WIRE HARN ASSY HANDLE MECHA VR	

7 ASSY PEDAL BASE (RTV-1100UK)

(D-1/1)

ITEM NO.	PART NO.	DESCRIPTION	NOTE
1	SPG-2200-01	ASSY BRAKE & ACCEL	
2	TOF-1501UK	PEDAL BASE	
3	FZR-1021UK	WIRE COVER BOX	
4	SPG-2222UK	ANTI FINGER TRAP PLATE L	
5	SPG-2223UK	ANTI FINGER TRAP PLATE R	
6	SPG-2224UK	PEDAL GASKET	
7	SPG-2031UK	NEOPRENE RUBBER STRIP 10	
101	280-A01200-A	ROUTER TWIST D12 ADH	
201	068-852216-0B	M8 WSHR 22OD FLT BLK	
202	030-000820-SB	M8X20 BLT W/S BLK	
203	000-P00408-WB	M4X8 MSCR PAN W/FS BLK	
204	050-F00400	M4 NUT FLG SER PAS	
301	600-9050-44K	WIRE HARN EART 500MM M4/M4 K	

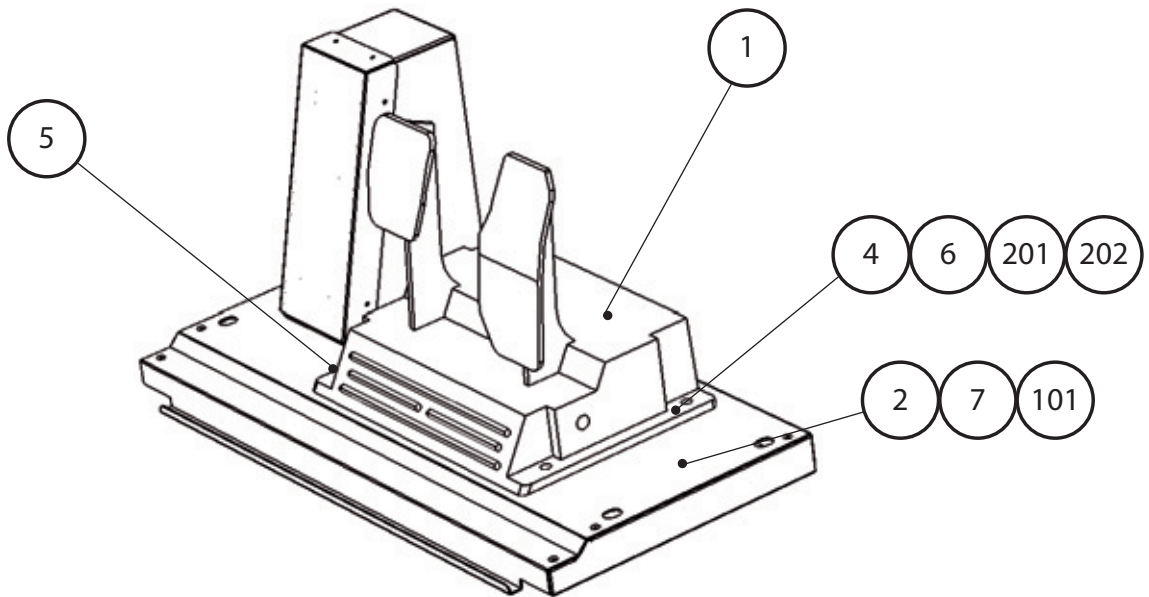

8 ASSY BILLBOARD (RTV-0500UK)

(D1/2)

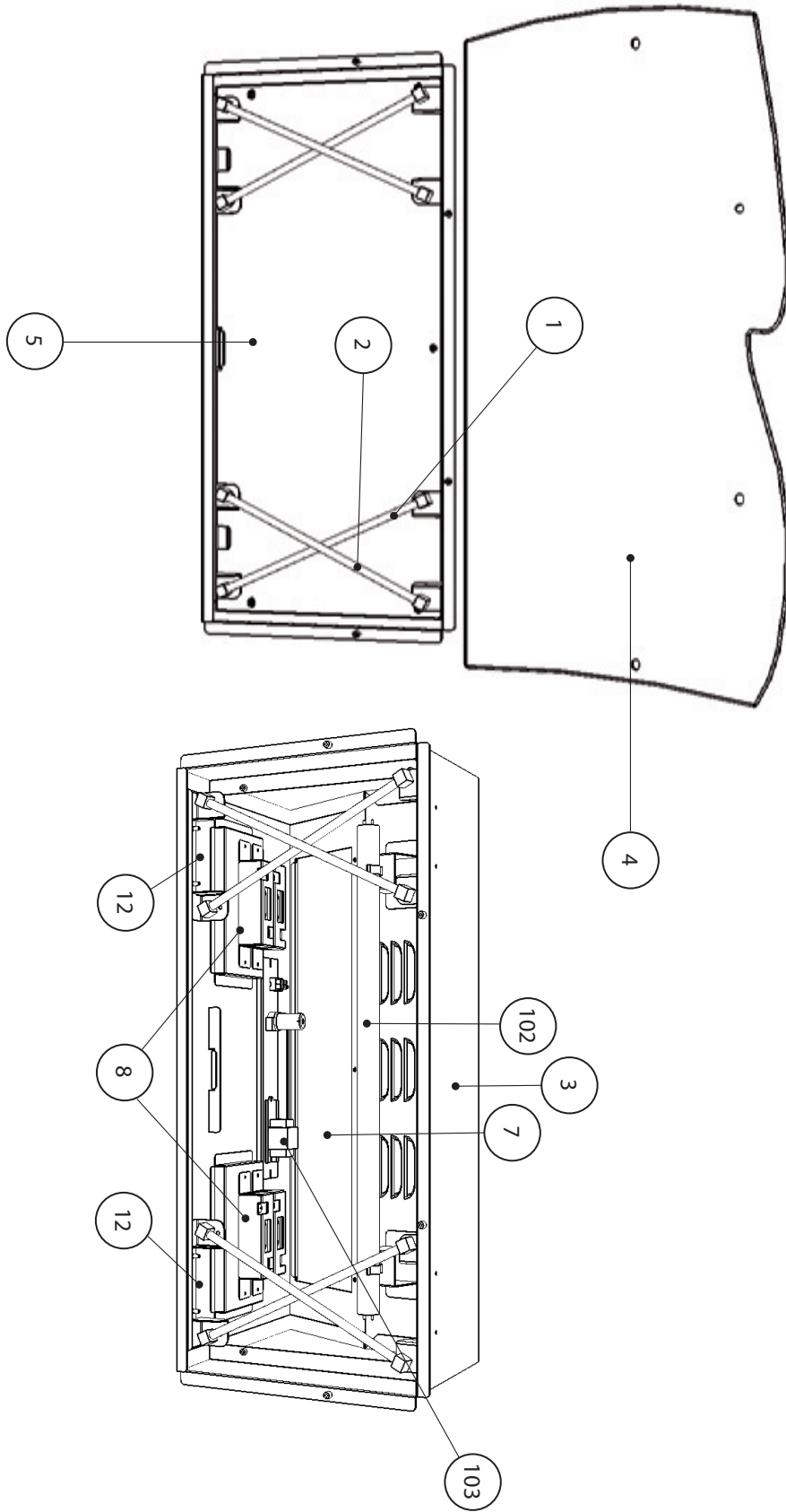

8 ASSY BILLBOARD (RTV-0500UK)**(D2/2)**

ITEM NO.	PART NO.	DESCRIPTION	NOTE
1	399-8300-BL-UK	CCFL KIT 300MM BLUE	
2	399-8300-RE-UK	CCFL KIT 300MM RED	
3	RTV-0501UK	BILLBOARD BOX	
4	RTV-0502	FRONT DESIGN PLATE	
5	RTV-0503UK	BACK DESIGN PLATE	
7	RTV-0505UK	BACK PLATE	
8	068-531210-PN	M5 WSHR 12OD FLT RUBBER	
12	RTV-0511UK	BRKT HOLDER CCFL	
15	LB1102	STICKER DANGEROUS VOLTAGE	
16	LB1104	STICKER CAUTION, HOT SURFACE	
102	390-0100-18DUK	FL TUBE 18W T8 600MM	
103	390-0100-18CUK	FL TRAY 100V 18W	
203	050-F00400	M4 NUT FLG SER PAS	
204	000-T00408-0C	M4X8 MSCR TH CRM	
205	068-441616-0C	M4 WSHR 16OD FLT CRM	
208	000-P00410-W	M4X10 MSCR PH PAS W/FS	
301	RTV-60045UK	WH SIGNAL CCFL BILLBOARD	
302	RTV-60046UK	WH AC BILLBOARD	

9 ASSY SEAT TWIN (RTV-1600UK)

(D1/1)

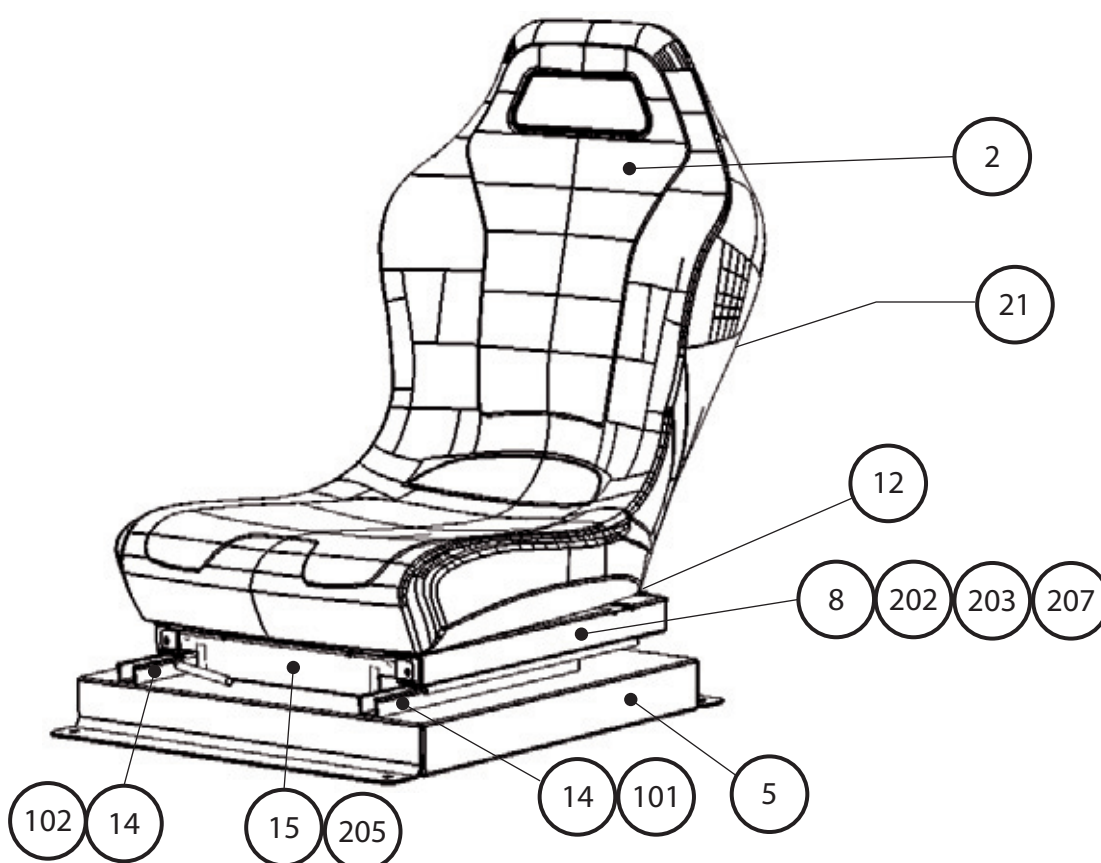

ITEM NO.	PART NO.	DESCRIPTION	NOTE
2	253-5550-0R	PAN DRIVING SEAT RED	
5	STC-1603	SEAT BASE	
8	RTV-1606UK	SEAT MOUNT TRAY	
12	STC-1610	SAFETY GUARD	
14	STC-1612	PROTECT RUBBER	
15	STC-1613	SAFETY GUARD F	
21	RTV-1603UK	STICKER SEAT BACK	
101	601-9059-91	SEAT RAIL L	
102	601-9060-91	SEAT RAIL R	
202	068-852216	M8 WSHR 22OD FLT PAS	
203	030-000830-S	M8 BLT W/S PAS	
205	000-T00408-0B	M4X8 MSCR TH BLK	
207	050-U00800	M8 NUT NYLOK PAS	

10 ASSY MAIN BD (RTV-4500UK)

(D-1/1)

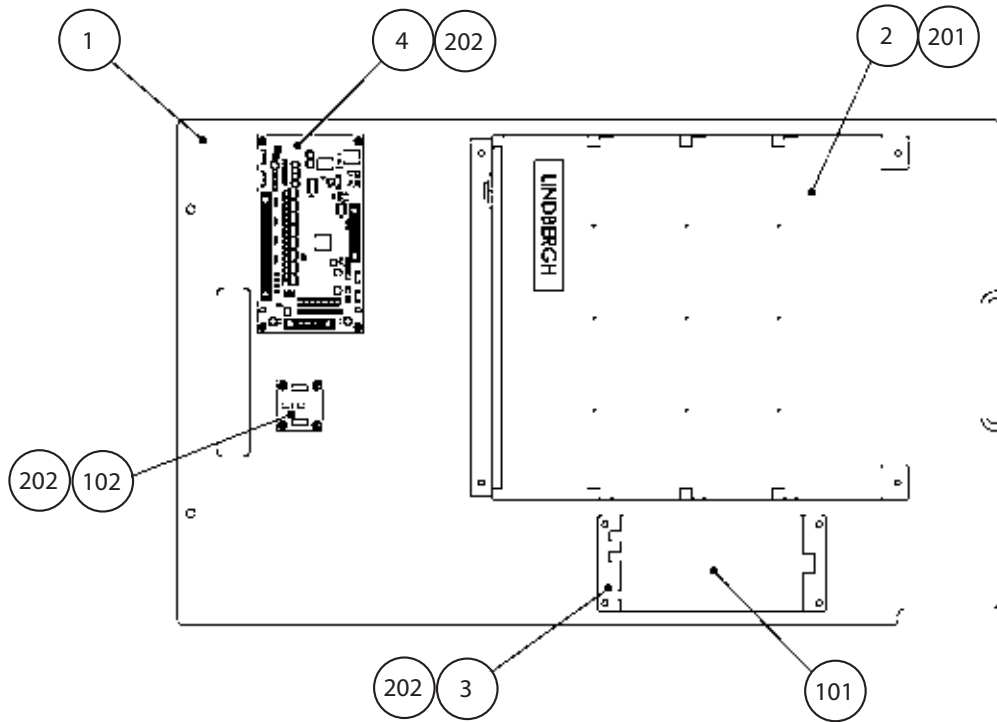

ITEM NO.	PART NO.	DESCRIPTION	NOTE
1	RTV-4501UK	BASE MAIN BD	
2	844-0001D-92-12	ASSY CASE LBG L 1GB 7800 EXP	
3	RTV-4502UK	ELEC BKT	
4	837-14572	PCB I/O CONTROL FOR JVS	
5	LB1111	STICKER PLEASE RECYCLE	
6	LB1101	STICKER WARNING BATTERY	
7	610-0727-0044	DVD SOFT KIT RTV	
101	400-5473	SW REGU ATX FOR LINDBERGH	
102	838-14578	CONVERT BD RS232/RS244	
104	280-A01264-WX	ROUTER TWIST D12 S06.4 WOOD X	
105	280-A02064-WX	ROUTER TWIST D20 S0.64 WOOD X	
201	000-P00416-W	M4X16 MSCR PAN W/FS PAS	
202	000-P00308	M3X8 MSCR PAN W/FS PAS	
301	RTV-60007UK	WH IO BD PWR MAIN BD	NOT SHOWN
302	RTV-60008UK	WH IO BD VOL MAIN BD	"
303	RTV-60010UK	WH IO BD SIGNAL MAIN BD	"
304	RTV-60011UK	WH SIGNAL CCFL MAIN BD	"
305	RTV-60012UK	WH DRIVER BD 422 MAIN BD	"
306	RTV-60013UK	WH AC MAIN BD	"
307	RTV-60014UK	WH AMP INPUT MAIN BD	"
308	ABX-60001UK	WH PWR LBG	"

11 ASSY ELEC BD (RTV-4600UK)

(D1/1)

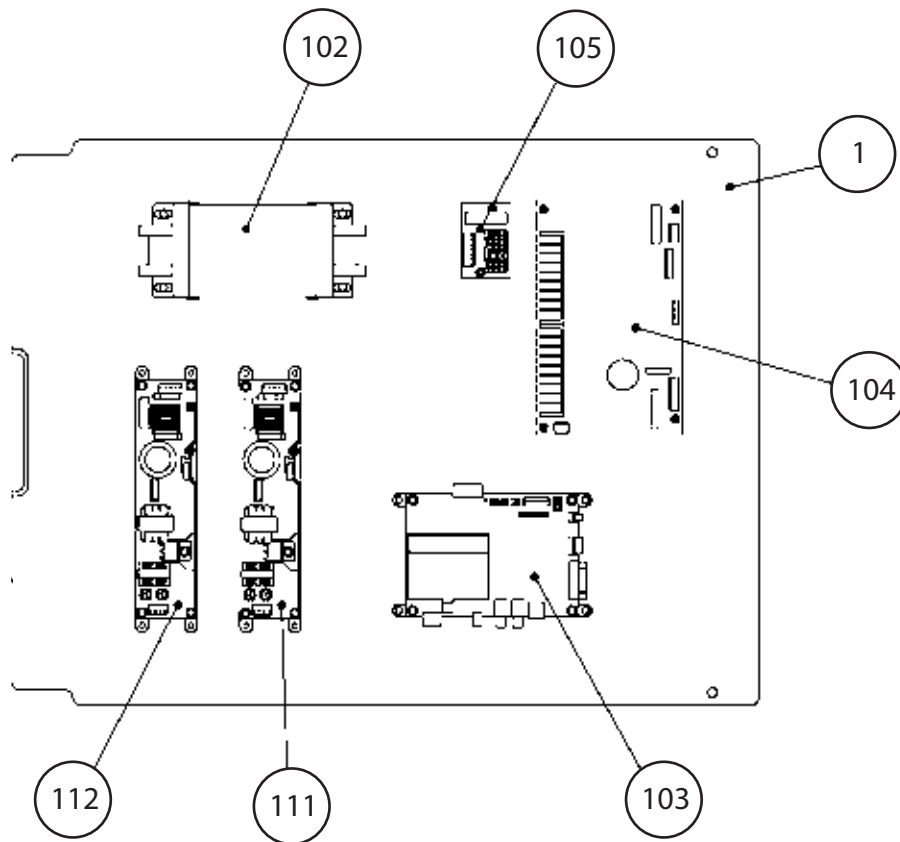

ITEM NO.	PART NO.	DESCRIPTION	NOTE
1	RTV-4601UK	WOODEN BASE ELEC	
102	560-LBGH-01UK	XFMR 220-240V 100V 8A	
103	838-14515-A0191	PCB AMP SND ANALOG IN	
104	838-14592-01	PCB SERVO MOTOR DRIVE SER EMI	
105	838-14551-02UK	PCB AC DISTRIBUTION	
111	400-050-024-01	PCB PSU 24VDC 50W MW LPS-50-24	
112	400-050-012-01	PCB PSU 12VDC 50W MW LPS-50-12	
301	FRI-61001UK	WH CONN BD IN	NOT SHOWN
302	600-7141-100UK	CABLE JVS USB 100CM	"
303	RTV-61001UK	WH CONN BD OUT A	"
305	RTV-60002UK	WH AMP OUTPUT ELEC BD	"
306	RTV-60003UK	WH AMP VOL ELEC BD	"
307	RTV-60004UK	WH AMP PWR ELEC BD	"
308	RTV-60005UK	WH AMP INPUT ELEC BD	"
309	RTV-60006UK	WH DRIVER BD 422 ELEC BD	"
310	RTV-60009UK	WH CCFL PWR ELEC BD	"
311	RTV-60047UK	WH EARTH FOR DRIVER JP	"
312	RTV-60048UK	WH CONN BD OUT B	"

12 ASSY BASE LID R (FRI-1510UK)

(D1-1)

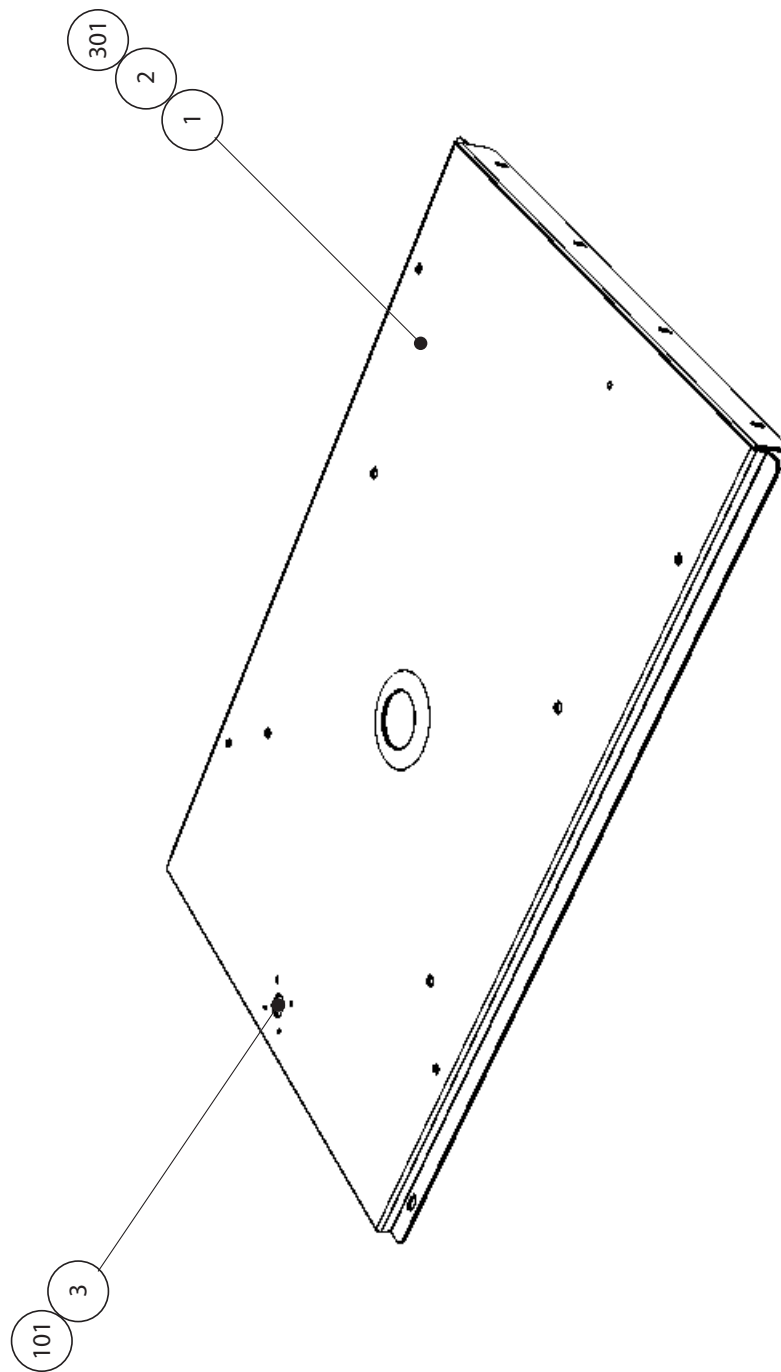

ITEM NO.	PART NO.	DESCRIPTION	NOTE
1	DUT-1511UK	BASE LID R	
2	DUT-1511-CUK	GASKET STRIP	
3	DUT-1511-DUK	LOCK TONGUE DUT	
101	220-5575UK	LOCK	
202	050-F00400	M4 NUT FLG SER PAS	
301	600-9020-44K	WH EARTH 200MM M4/M4 K	

13 ASSY COIN CHUTE TOWER (RTV-0300UK)

(D1-1)

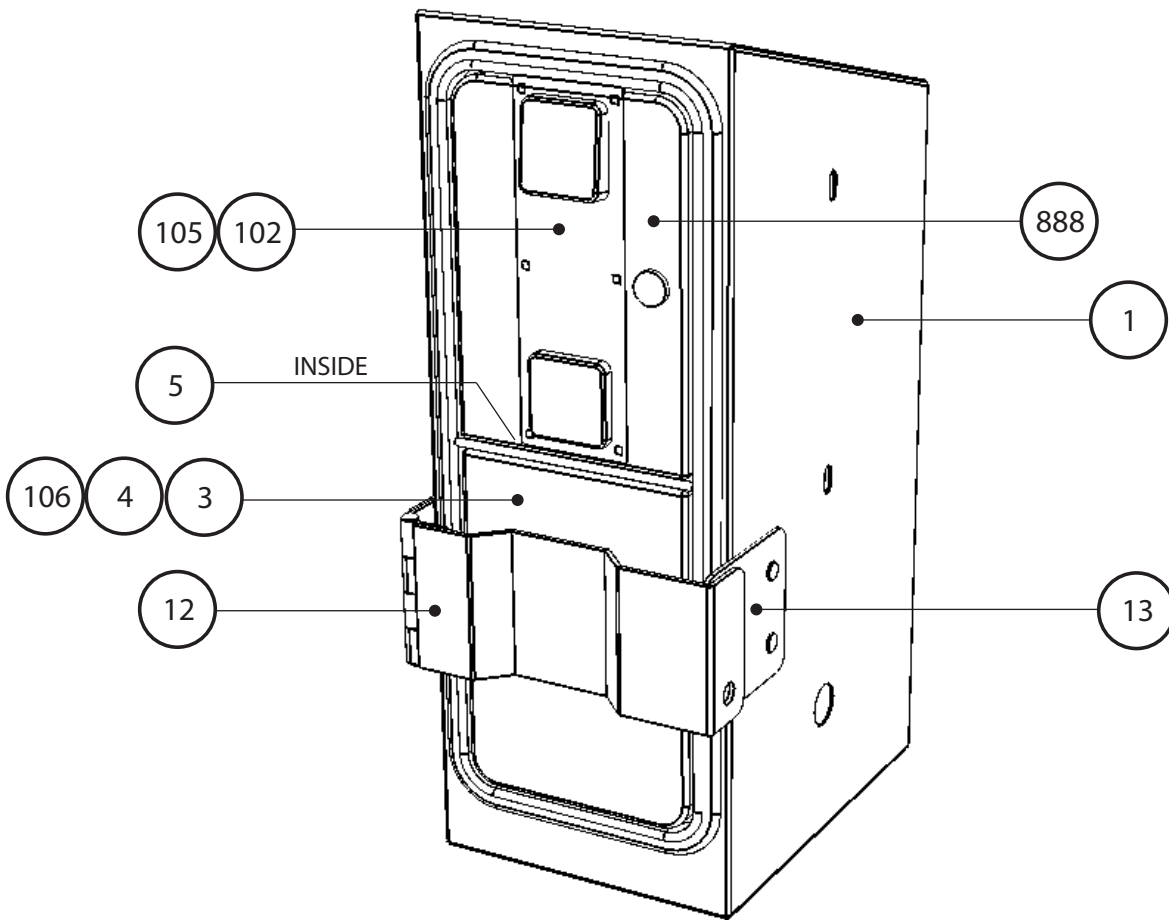

ITEM NO.	PART NO.	DESCRIPTION	NOTE
1	RTV-0301UK	COIN CHUTE TOWER	
2	VTS-FRI-T-R	PCB VTS FRI TWIN	
3	PP1087	CASH BOX FOR MINI DOOR	
4	RTV-0302UK	CCT FLOOR RTV	
5	DUT-0302UK	PLATE COIN PATH	
11	LB1103	STICKER CAUTION	
12	TFF-0304UK	LOCKING HASP	
13	TFF-0305UK	BKT PADLOCK	
101	220-5374-01	DOOR DFMD W/FR & LOCK C120 UNIV	
102	220-5574UK	LOCK (J9117) KEY TO LIKE 22MM W CAM	
105	220-5610-01	SR3 STD BODYBSR3INGB	
106	220-5727-01B	DOOR CASH H.S. STS	
201	000-P00308-WB	M3X8 MSCR PAN WLFS BLK	
204	050-U00800	M8 NYLOK NUT PAS	
205	068-852216	M8 WSHR 22OD FLT PAS	
301	RTV-60100UK	WH VTS	
302	LM1006LOR	WH COIN LAMP	

14 ASSY WIRE COVER RTV TWIN

(D1/1)

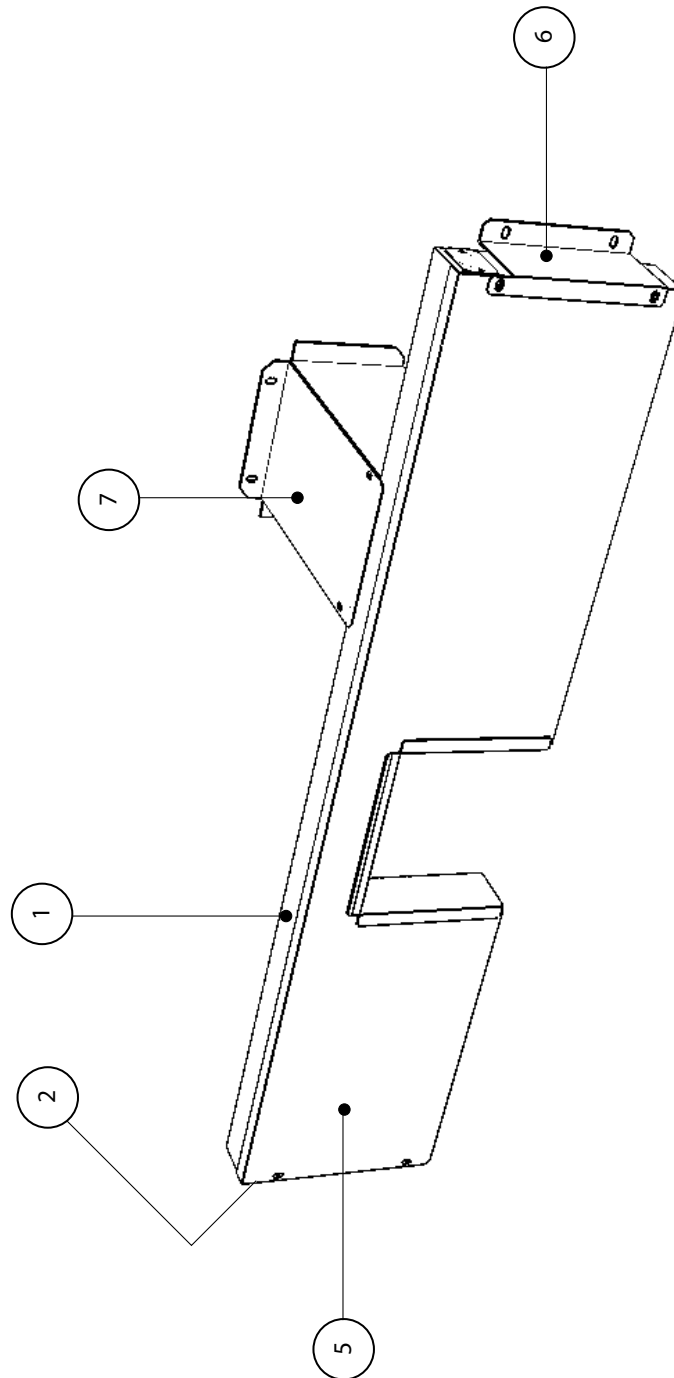

ITEM NO.	PART NO.	DESCRIPTION	NOTE
1	DYN-0005UK	AC COVER A	
2	DYN-0009UK	HOLE LID	
201	000-P00308-WB	M3X8 MSCR PAN W/FS BLK	
202	050-F00400	M4 NUT FLG SER PAS	
203	280-A02000-A	ROUTER TWST D20 ADH	
301	600-68171-04	WIRE HARN EXT AC (SPG)	
302	RTV-60101UK	WH P1 VTS EXT	
303	RTV-60102UK	WH P2 VTS EXT	
304	RTV-60103UK	WH CREDITS EXT A	
305	600-9075-44K	WH EARTH 750MM M4/M4 K	
306	600-9030-44K	WH EARTH 300MM M4/M4 K	
307	600-9040-45K	WM EARTH 499MM M4/M5 K	

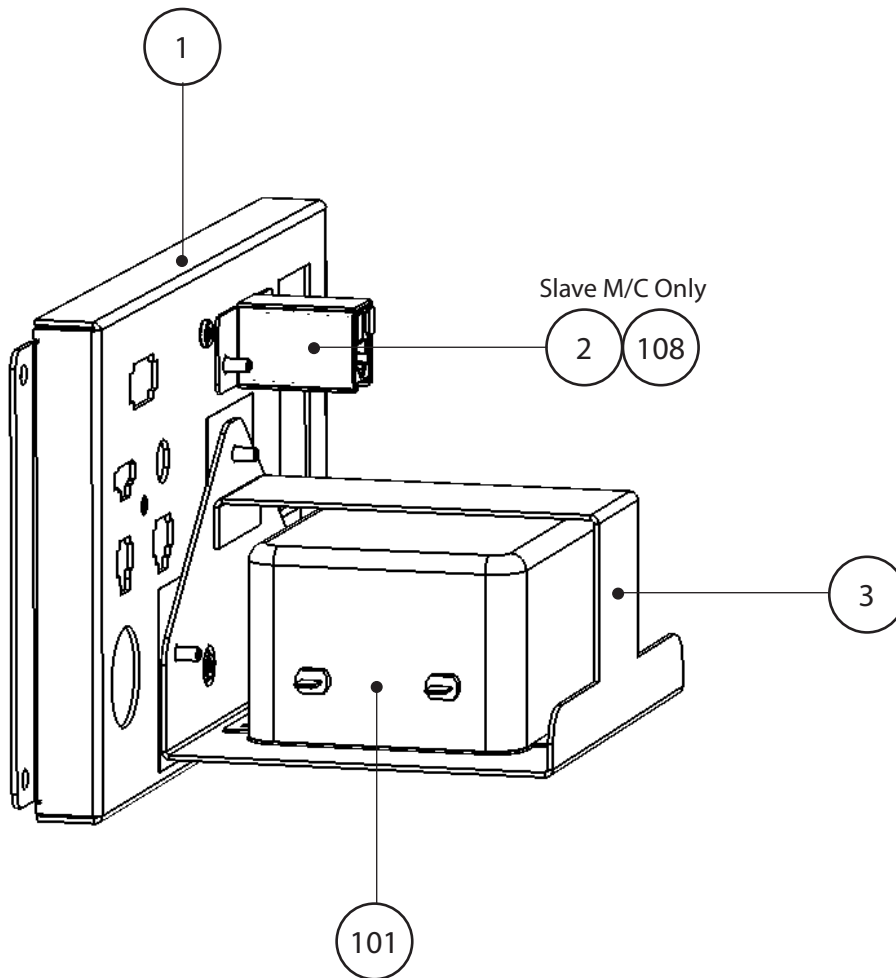

ITEM NO.	PART NO.	DESCRIPTION	NOTE
1	RTV-0401UK	AC BKT UK	
3	RTV-0403UK	FILTER BRKT	
101	EP1382	SCHAFNER NOISE FILTER	
102	EP1387	IEC INLET SW FUSED	
104	514-5078-5000	FUSE 5X20 CERAMIC SB 5000MA	
105	310-5029-D508	HEAT SHRINK SLEEVE 50.8D	
106	421-6595-5000-T	STICKER FUSE 5000MA	
107	LB1096	STICKER PROTECTIVE EARTH	
111	EP1334	FUSE HOLDER 20MM 10A 240VAC	
112	514-5078-5000	FUSE 5X20 CERAMIC SB 5000MA	
113	421-6595-10000T	STICKER FUSE 10000MA TYPE T	
114	360168	SNAP BUSHING HEYCO 400-2182	
203	000-P00308-W	M3X8 MSCR PAN W/FS PAS	
204	050-F00400	NUT M4 FLG SER PAS	
301	600-6873-01	WH XFMF IN	
303	600-9030-44K	WH EARTH 300MM M4/M4 K	
304	600-9040-45K	WH EARTH 400MM M4/M5 K	

Please see item 15 (ASSY AC BKT MAIN)
for diagram

ITEM NO.	PART NO.	DESCRIPTION	NOTE
1	RTV-0401UK	BKT AC UK	
2	TFF-0402UK	CONN COVER	
106	421-6595-5000-T	STICKER FUZE 5000MA	
107	LB1096	STICKER PROTECTIVE EARTH	
108	EP1391	COUPLER INLINE LAN RJ45 UTP	
111	EP1334	FUSE HOLDER 20MM 10A 240V	
112	514-5078-5000	FUSE 5X20 CERAMIC 5000MA TYPE T	
114	360168	SNAP BUSHING HEYCO 400-2182	
204	050-F00400	M4 NUT FLG SER PAS	
303	600-9030-44K	WH EARTH 300MM M4/M4 K	
304	600-9040-45K	WH EARTH 400MM M4/M5 K	
305	600-6999-201UK	WH SUB AC BKT	

17 ASSY ACCEL&BRAKE (SPG-2200-01)

(D-1/2)

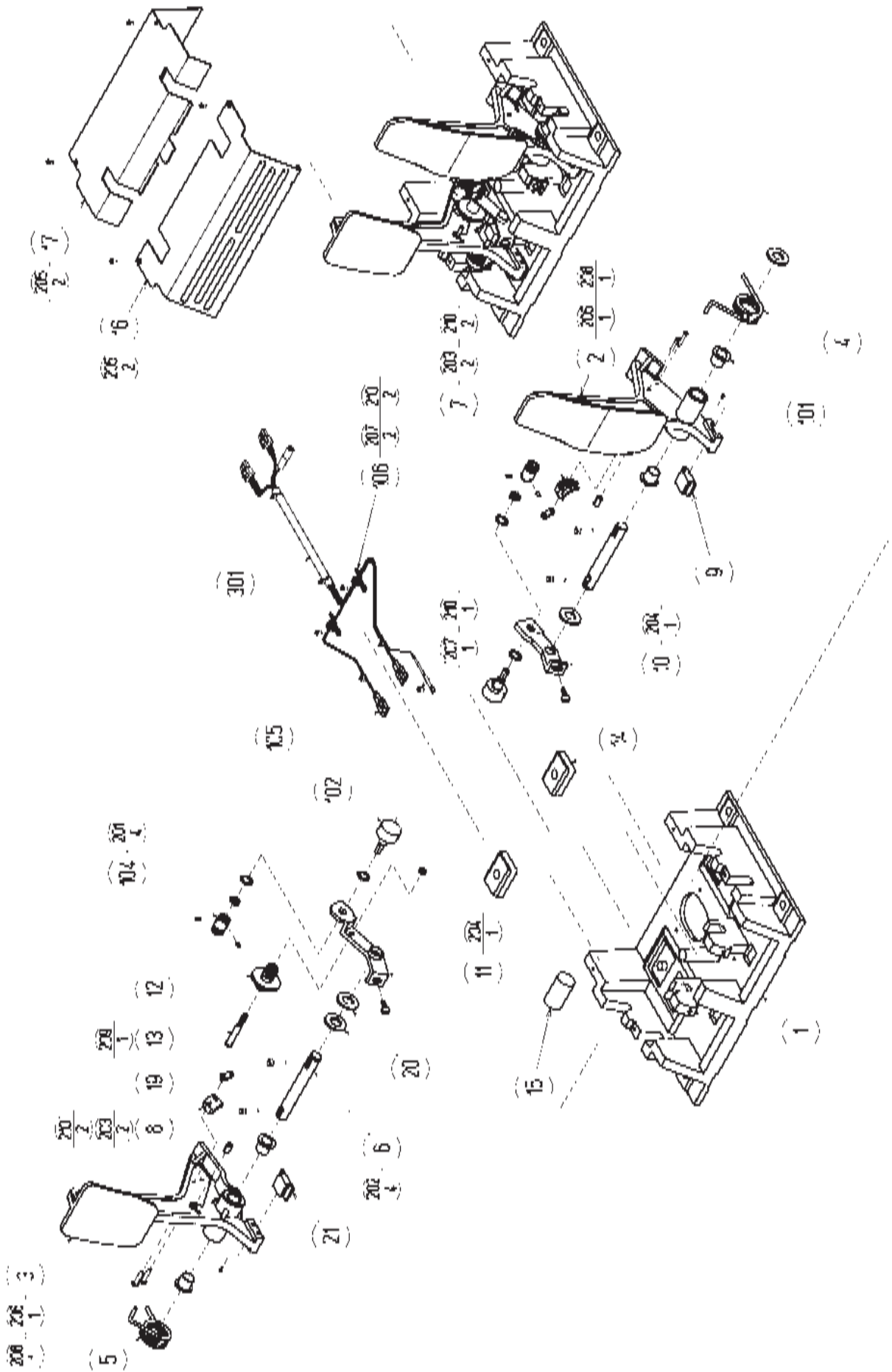

17 ASSY ACCEL&BRAKE (SPG-2200-01)**(D-2/2)**

ITEM NO.	PART NO.	DESCRIPTION	NOTE
1	SPG-2201	BASE	
2	SPG-2202	ACCEL PEDAL	
3	SPG-2203	BRAKE PEDAL	
4	SPG-2204	ACCEL SPRING	
5	SPG-2205	BRAKE SPRING	
6	SPG-2206	SHAFT	
7	SPG-2207	ACCEL GEAR	
8	SPG-2208	BRAKE GEAR	
9	SPG-2209	NEUTRAL STOPPER	
10	SPG-2210	VR PLATE ACCEL	
11	SPG-2211	VR PLATE BRAKE	
12	SPG-2212	AMPL GEAR	
13	SPG-2213X	GEAR SHAFT	
14	SPG-2214	STOPPER	
15	SPG-2215	RUBBER CUSHION	
16	SPG-2216	COVER	
17	SPG-2217	VR COVER	
19	SPG-2219	GEAR STAY	
20	SPG-2220	WSHR	
21	SPG-2221	NEUTRAL STOPPER D	
101	100-5263	BEARING 12(OILES 80F-1212)	
102	220-5484	VOL CONT B-5K OHM	
102	220-5753	VOL CONT B-5K OHM (TOCOS)	
104	601-7944	GEAR 15	
105	310-5029-F15	SUMITUBE F F15MM	
106	280-0419	HARNES LUG	
201	028-A00304-P	SET SCR HEX SKT CUP P M3x4	
202	020-000520-OZ	HEX SKT H CAP SCR BLK M5x20	
203	000-P00420	M SCR PH M4x20	
204	000-P00512-W	M SCR PH W/FS M5x12	
205	000-T00408-0C	M SCR TH CRM M4x8	
206	FAS-450005	SPR PIN BLK OZ 6x10	
207	000-P00405	M SCR PH M4x5	
208	FAS-000001	M SCR TH CRM M3x6	
209	050-H00500	HEX NUT M5	
210	060-F00400	FLT WSHR M4	
301	600-6840-01	WIRE HARN ACCEL&BRAKE YL	

18 ASSY SPEAKER L (ABX-1960UK)

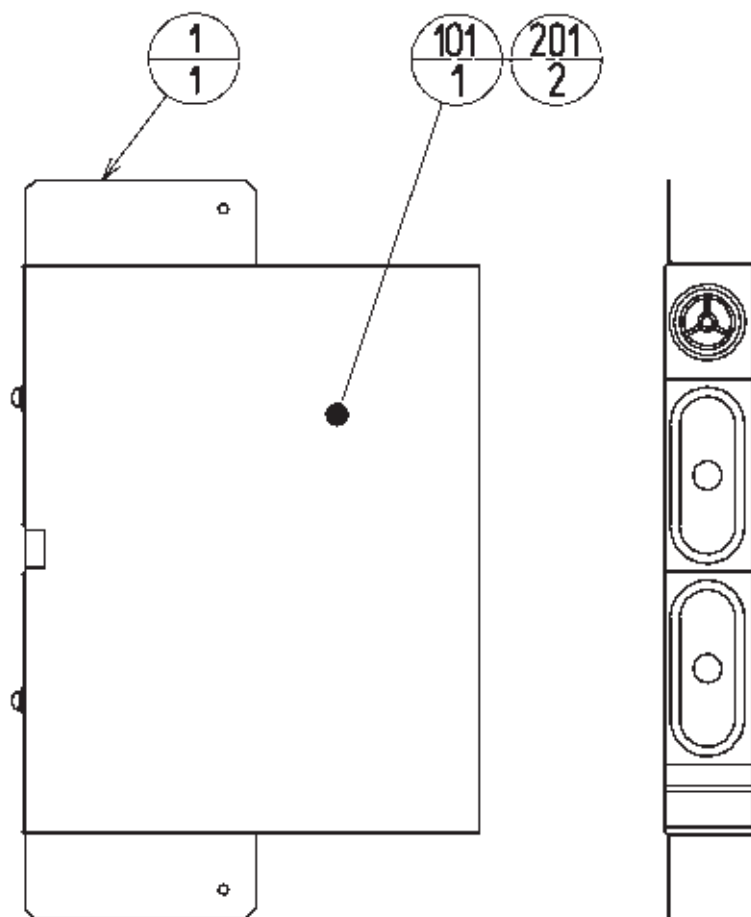

ITEM NO.	PART NO.	DESCRIPTION	NOTE
1	APC-1561UK	SPEAKER BRKT	
101	130-5156-02	SPEAKER BOX 8OHM 20W VA1 YL	
201	000-P00512-W	M SCR PH W/FS M5x12	

19 ASSY SPEAKER R (ABX-1965UK)

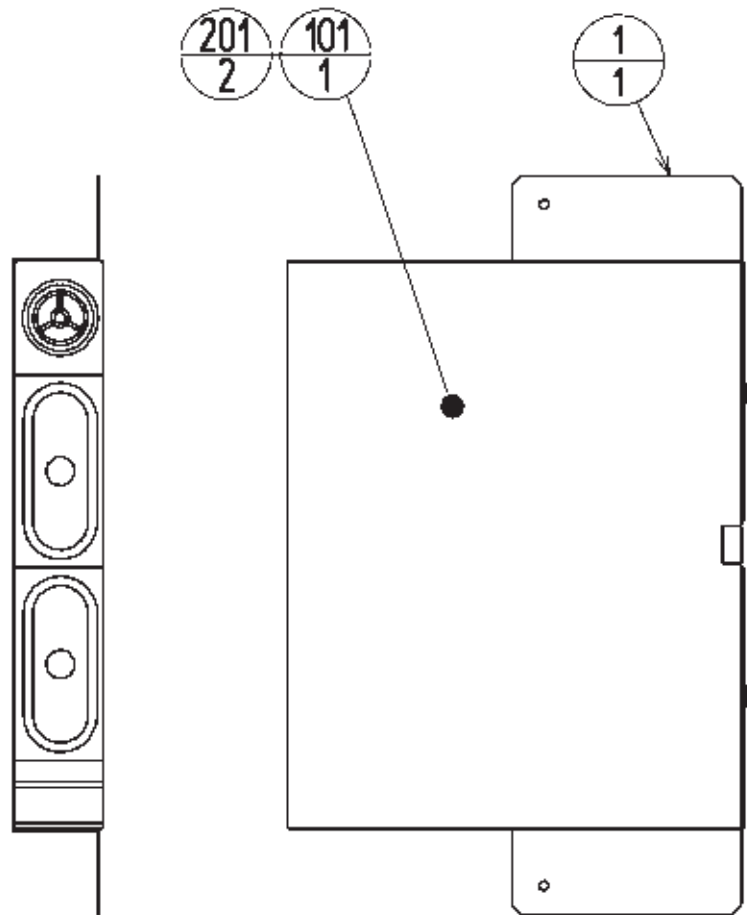

ITEM NO.	PART NO.	DESCRIPTION	NOTE
1	APC-1561X	SPEAKER BRKT	
101	130-5156-02	SPEAKER BOX 8OHM 20W VA1 YL	
201	000-P00512-W	M SCR PH W/FS M5x12	

20 ASSY SW PLATE (RTV-2100)

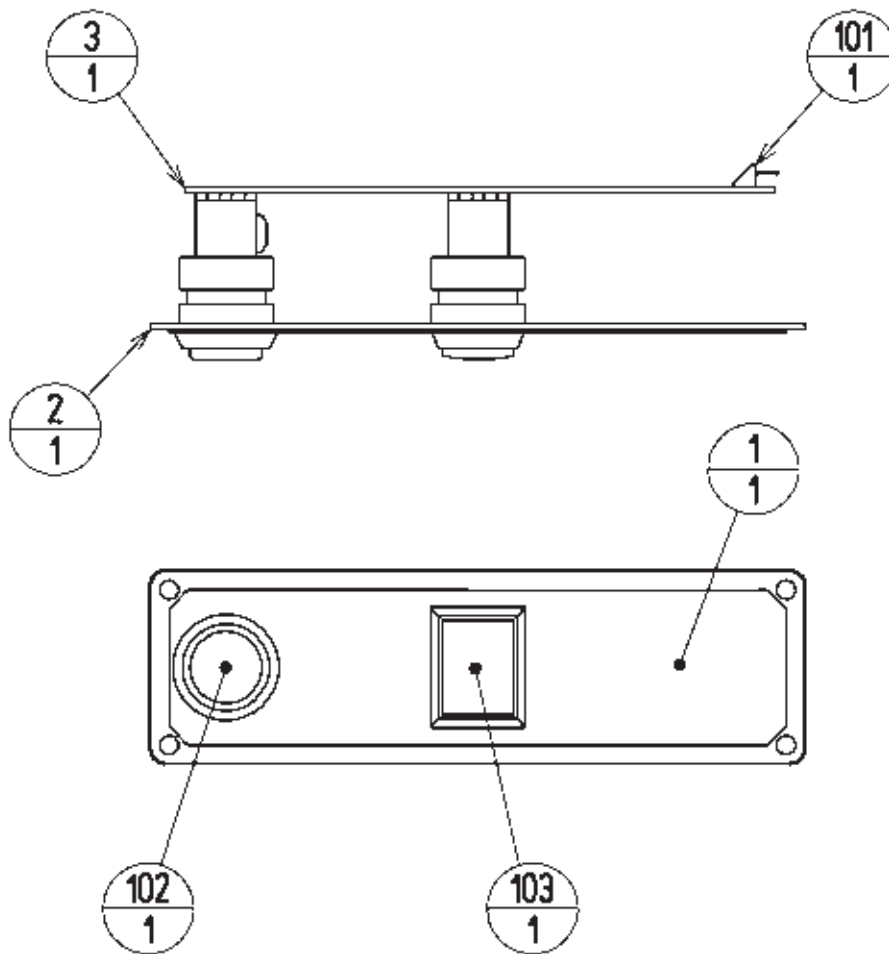

NOTE: When attaching the STICKER, line it up with the hole.

ITEM NO.	PART NO.	DESCRIPTION	NOTE
1	RTV-2101	STICKER START/VIEW	
2	ORT-2101	BUTTON PLATE	
3	171-6478B	PC BD LIGHTING SWX5	
101	212-5205-12	CONN JST M 12P RTA	
102	509-5560-Y-91	PB SW W/L 6V 1L Y ROHS	
103	509-5561-R-91	PB SW W/L 6V 5L R ROHS	

22 WIRE COLOR CODE TABLE

⚠ WARNING

The DC power wire color for this product is different from previous SEGA titles. Working from the previous wire colors will create a high risk of fire.

The color codes for the wires used in the diagrams in the following chapter are as follows.

A	PINK
B	SKY BLUE
C	BROWN
D	PURPLE
E	LIGHT GREEN

Wires other than those of any of the above 5 single colors will be displayed by 2 alphanumeric characters.

1	RED
2	BLUE
3	YELLOW
4	GREEN
5	WHITE
7	ORANGE
8	BLACK
9	GRAY

If the right-hand side numeral of the code is 0, then the wire will be of a single color shown by the left-hand side numeral (see the above).

Note 1: If the right-hand side numeral is not 0, that particular wire has a spiral color code. The left-hand side character shows the base color and the right-hand side one, the spiral color.

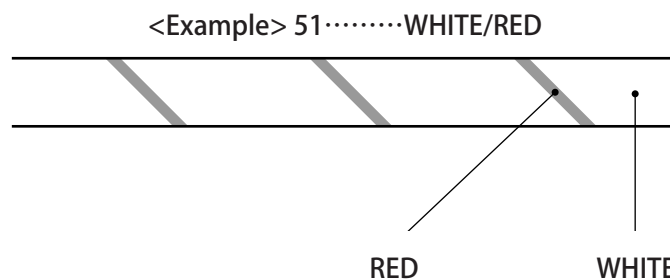

Note 2: The character following the wire color code indicates the size of the wire.

U:	AWG16
K:	AWG18
L:	AWG20
None:	AWG22

23 WIRING DIAGRAM (D-1/3)

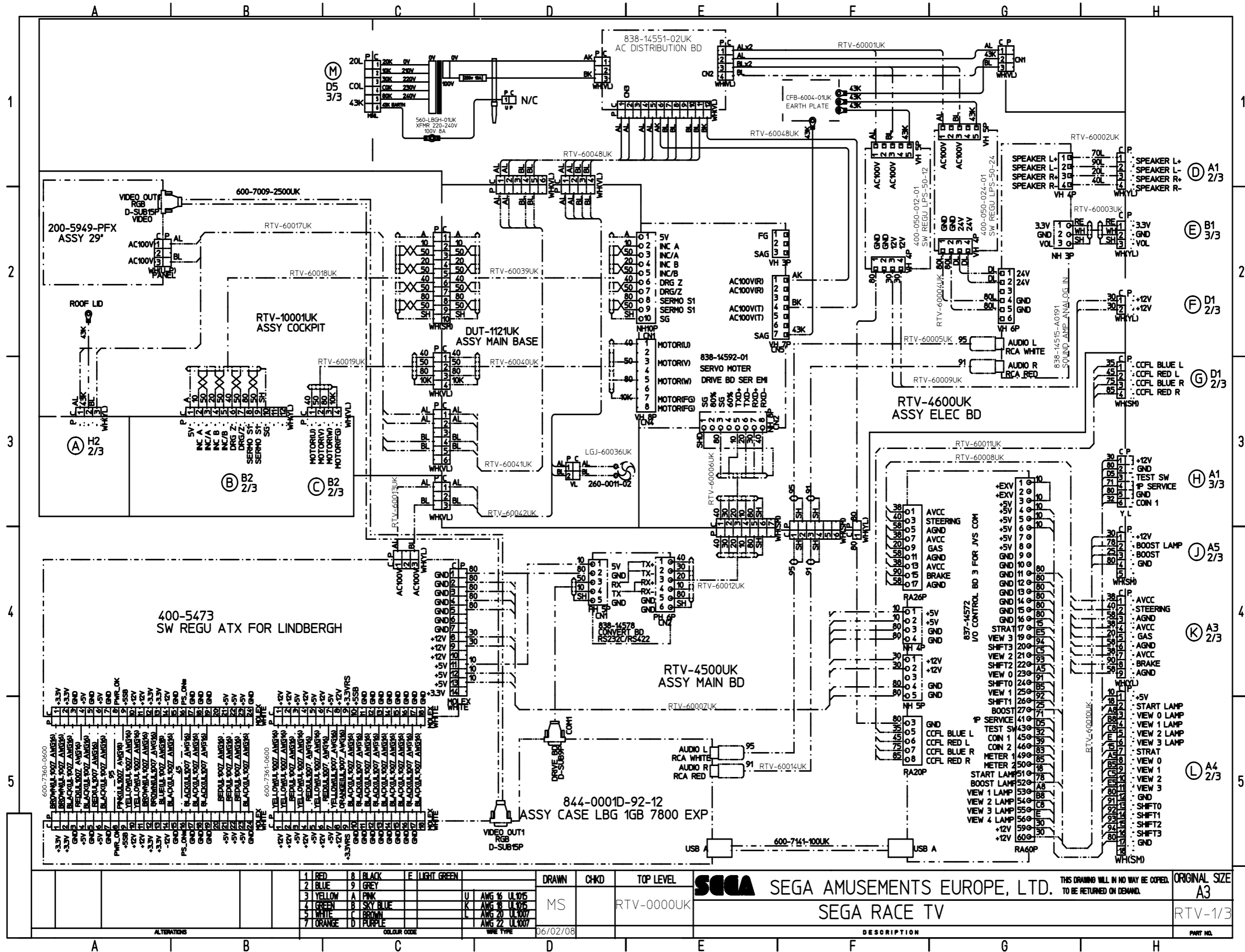

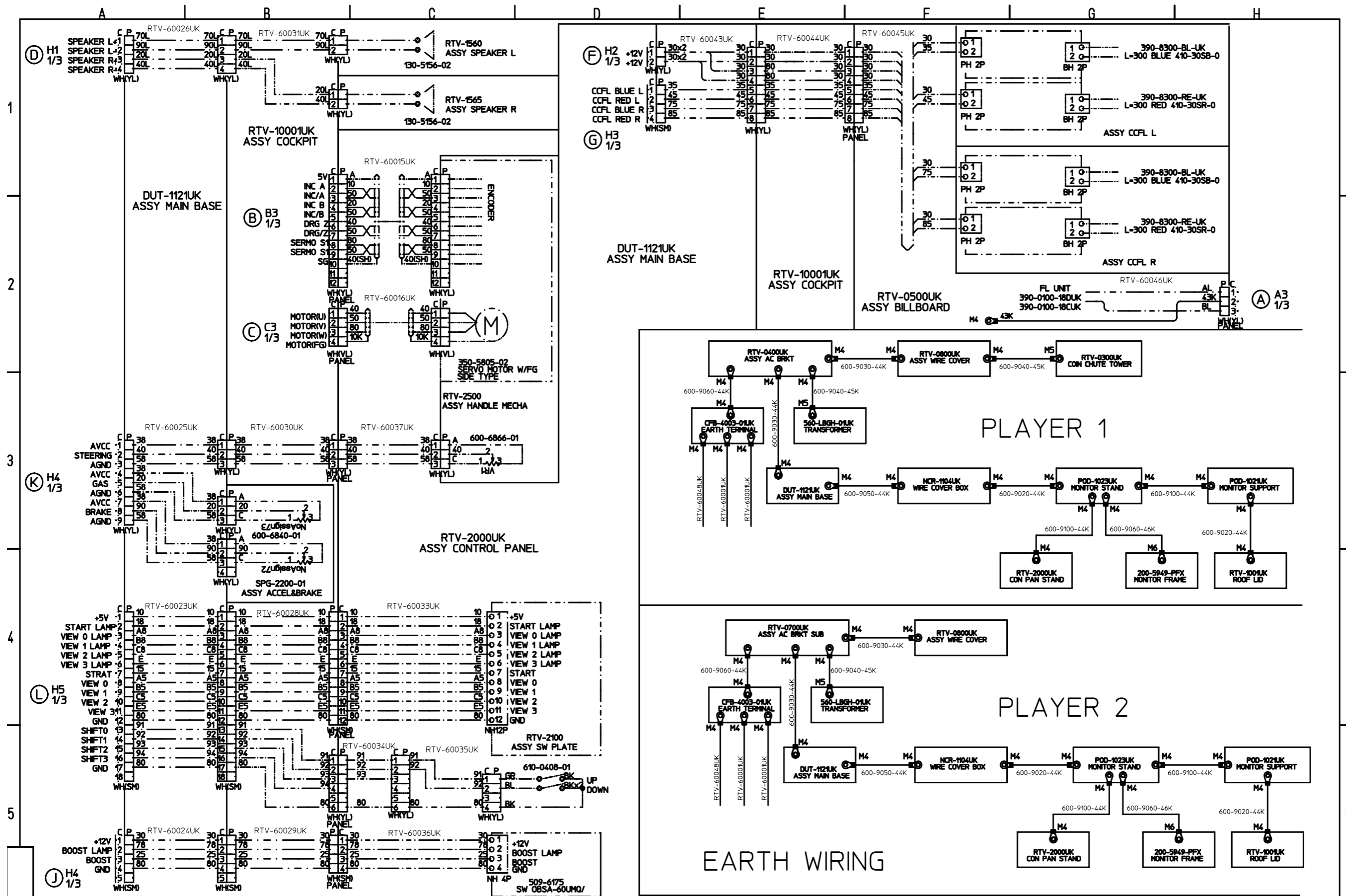

1 RED		8 BLACK		E LIGHT GREEN		DRAWN	CHKD	TOP LEVEL	SEGA SEGA AMUSEMENTS EUROPE, LTD.	THIS DRAWING WILL IN NO WAY BE COPIED TO BE RETURNED ON DEMAND.	ORIGINAL SIZE
2 BLUE		9 GREY				MS		RTV-0000UK			A3
3 YELLOW		A PINK							SEGA RACE TV		RTV-2/3
4 GREEN		B SKY BLUE							DESCRIPTION		PART NO.
5 WHITE		C BROWN									
7 ORANGE		D PURPLE									
ALTERNATIONS		COLOUR CODE		WIRE TYPE		36/02/08					

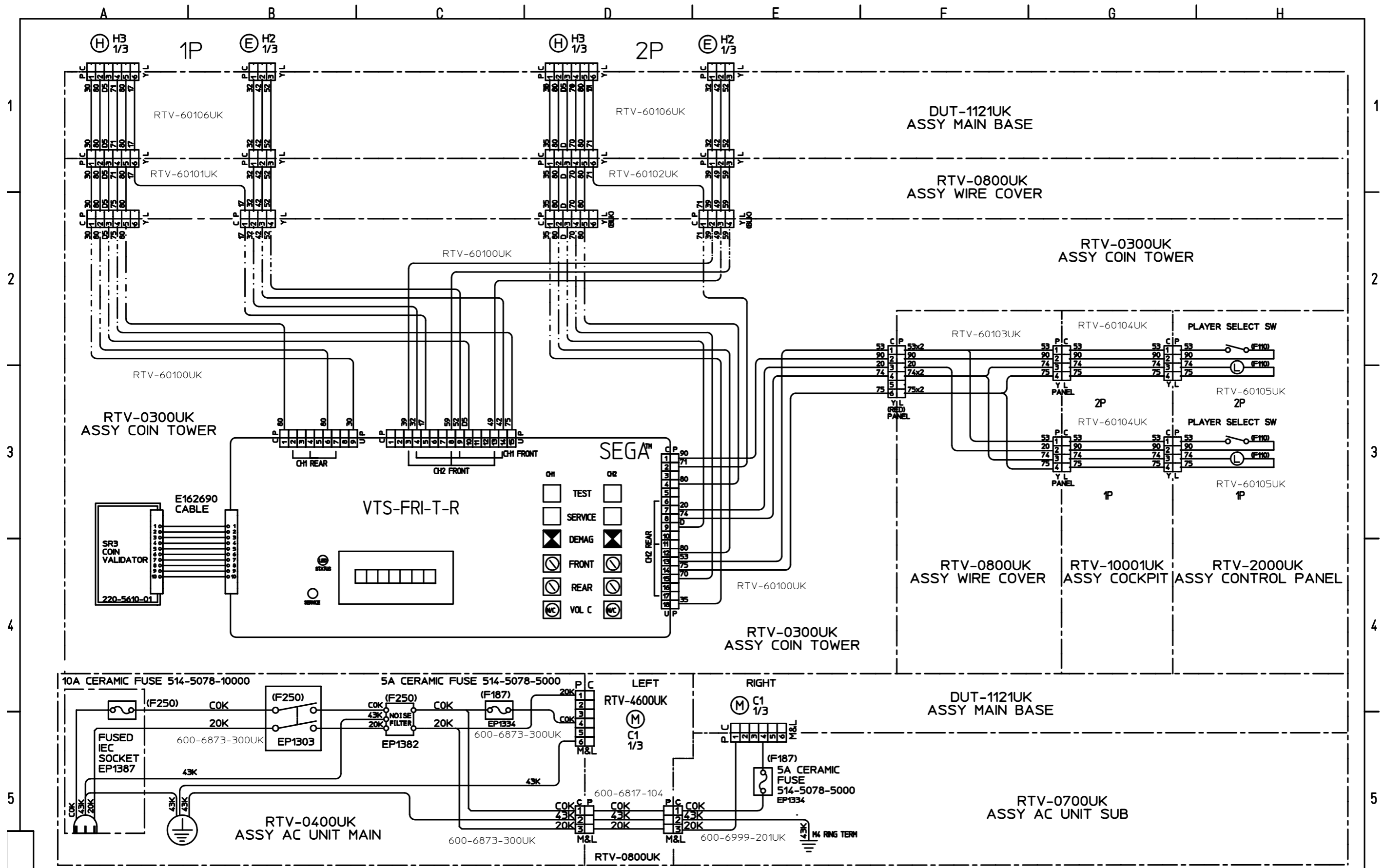

1 RED	8 BLACK	E LIGHT GREEN
2 BLUE	9 GREY	
3 YELLOW	A PINK	U ANG 16 UL105
4 GREEN	B SKY BLUE	K ANG 18 UL105
5 WHITE	C BROWN	L ANG 20 UL1007
7 ORANGE	D PURPLE	ANG 22 UL1007

DRAWN	CHKD	TOP LEVEL
MS		RTV-0000UK
06/02/08		

	SEGA AMUSEMENTS EUROPE, LTD.	THIS DRAWING WILL IN NO WAY BE COPIED, TO BE RETURNED ON DEMAND.	ORIGINAL SIZE A3
	SEGA RACE TV		RTV-3/3
DESCRIPTION			PART NO.